

SCHMEISER MID-ROW RIPPER™

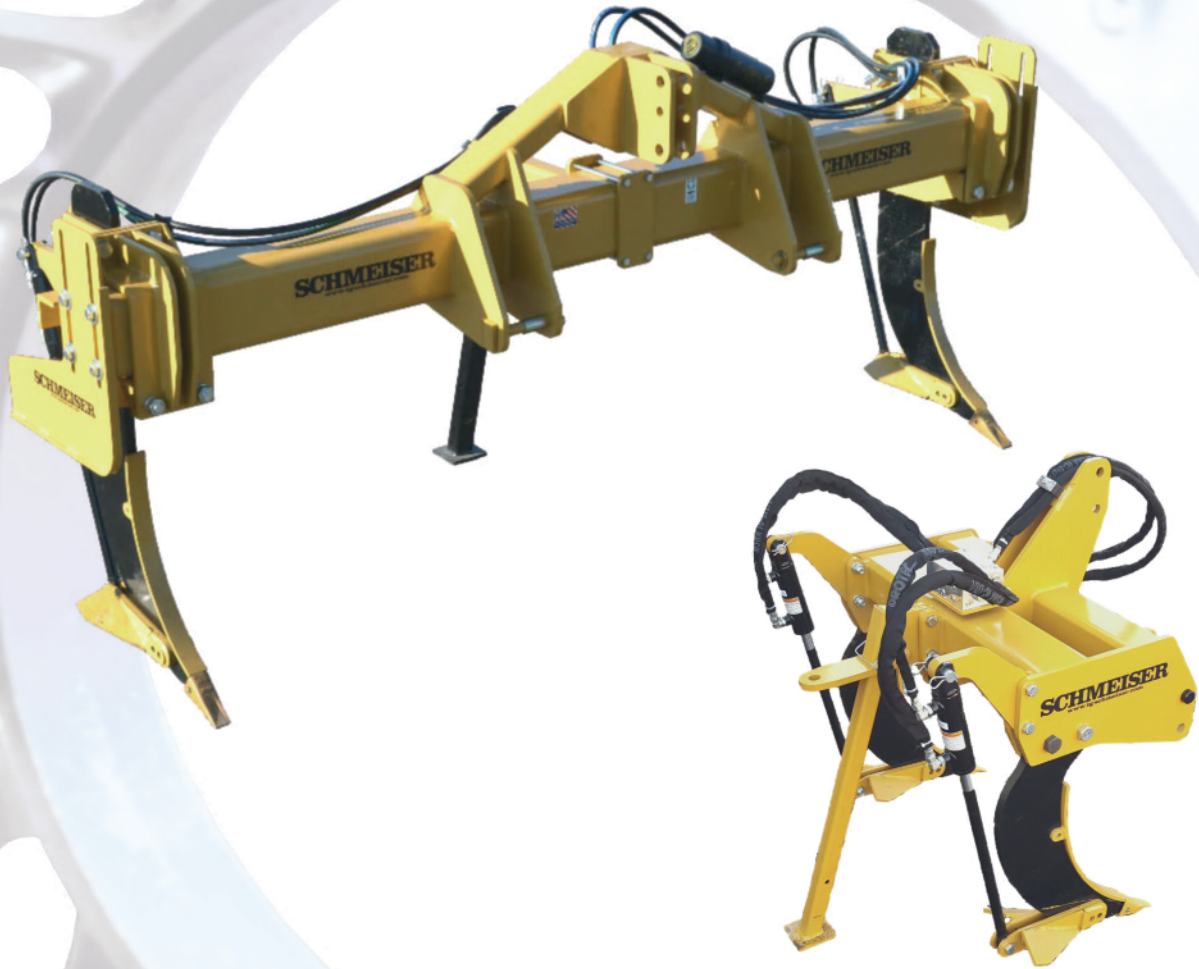

T. G. SCHMEISER Co., Inc.

OPERATION AND PARTS MANUAL

Version 2.3
January 2023

Read and understand the manual. This manual provides information and procedures to safely operate and maintain the Mid Row Ripper.





CONTENTS

INTRODUCTION.....4	General Operating Instructions.....20
Engineered for Long Life.....4	Operating Recommendations.....21
Serial Number Information.....4	Detaching From Tractor.....21
Replacement Parts.....4	
Warranty Information.....4	
Serial Number Location.....4	
Factory Contact Information.....4	
Dealer Contact Information.....4	
SAFETY.....5	REAR ROLLERS (Optional Equipment).....22
Safety Alert Symbols.....5	Till An' Pak™ Rear Rollers.....22
Safety Icons Nomenclature.....6	Down Pressure Rear Rollers with Steel Star Rings.....22
Personal Protection/Important Information.....6	Gauging Adjustment.....23
Prohibited Actions.....6	Rear Rollers Gauging Depths Table.....23
Hazard Avoidance.....6	
General Safety.....7	
Assembly Safety.....7	
Transport Safety.....8	
Highway and Transport Operation.....8	
Operation Safety.....8	
Tractor Requirements.....9	
Tractor Safety Devices.....9	
ROPS and Seat Belt.....9	
Connecting to Tractor.....9	
Hydraulic Components Safety.....9	
Maintenance Safety.....10	
Bolt Torque Requirements.....11	
Welding Repairs.....11	
Storage Safety.....11	
Disposal of Equipment at End of Useful Life.....11	
	MAINTENANCE.....24
	Lubrication Points.....24
	Wing Pivot Pins.....24
	Rear Roller Bearings (Optional).....24
	Roller Frame Mounting Bushings (Optional).....24
	Ground Engaging Components.....24
	Shank Points.....24
	Shank Wings LH and RH.....25
	Shank Wing Pivot Pin and Cap.....25
	Shank Shin Guards.....25
	Maintenance Schedule.....26
	STORAGE.....27
	Storage Preparation.....27
	Placing In Storage.....27
	Removing From Storage.....27
	COMPONENT NOMENCLATURE.....28
	HD Mid-Row Ripper™.....28
	Mini Mid-Row Ripper™.....29
SAFETY SIGNS AND DECALS.....12	PARTS SECTION.....30
Safety Sign Placement.....12	Ordering Parts.....30
Safety Signs and Decals.....13	HD Mid-Row Ripper™ Assembly.....30
	Mini Mid-Row Ripper™ Assembly.....31
	48" Adjustable Shank Assembly (HD).....32
	30" Parabolic Shank Assembly (Mini).....33
	Till An' Pak™ Rear Roller Assembly (Optional).....34
	Down Pressure Rear Roller Assembly (Optional).....35
	HD Extension Assembly (Optional).....36
	Mid-Row Ripper™ HD Dirt Crowder Assembly (Optional).....37
	HYDRAULIC DIAGRAM.....38
	Mini and HD Mid Row Ripper Model Diagram.....38
	LIMITED WARRANTY STATEMENT.....39
SPECIFICATIONS.....14	
Mini Mid-Row Ripper™.....14	
Heavy Duty Mid-Row Ripper™.....15	
Tractor Requirements.....16	
Horse Power Requirements.....16	
Hydraulic Requirements.....16	
3-Point Hitch.....16	
OPERATION.....17	
Attaching to Tractor.....17	
Connecting to Tractor Hydraulics.....17	
Setting the Mid-Row Ripper™.....18	
Initial Set Up Check List.....18	
Adjusting HD Mid-Row Ripper™ Shanks.....18	
Adjusting Shanks Depth.....19	
Adjusting Shanks Spacing.....19	
Implement Break-In.....20	

INTRODUCTION

Your **Schmeiser Mid-Row Ripper™** (implement) is the ideal root zone management system with impressive results and tremendous acceptance for use in both vineyard and orchard applications.

The Agsoilworks™ Mid-Row Ripper™ was originally designed in Australia through collaboration of Agsoilworks'™ founder Randal Tomich, soil scientists and the Australia Commonwealth Research Organization (CSIRO). Twenty years of effort has resulted in a proven patented tool and system providing superior ripping, soil breakout, soil blending and better root zones.

Randal Tomich brought the technology to John Crossland in California and the two collaborated in pioneering precision pre-plant ripping of vineyards and orchards with their GPS guided development Vibrosoiler™. They also built smaller versions for eliminating compaction in orchard and vineyard soils. Now T.G. Schmeiser with collaboration with Agsoilworks™, provide you with the best system for root zone management, the Schmeiser Agsoilworks™ Mid-Row Ripper™.

The success of the Schmeiser Mid-Row Ripper™ is attributed to the oscillating hydraulic wing design that helps fracture, lift, and blend soil. It goes deep and opens soil for a healthier root structure. That means deeper water penetration, better soil aeration, and soil amendment mixing for your orchard or vineyard.

This manual has been prepared to instruct the user in the safe and efficient operation of this implement. Read and understand the manual thoroughly and follow all instructions carefully.

Engineered for Long Life

The Schmeiser Mid-Row Ripper™ is designed to provide many years of dependable service when used and maintained properly.

Serial Number Information

Record the serial number, model number, and date purchased in the space provided in the Serial Number Location section. Be sure to have this information whenever contacting the dealer to order parts or attachments for this implement.

Replacement Parts

Should this implement require replacement parts, contact your local Schmeiser dealer. Always order genuine Schmeiser OEM replacement parts.

Warranty Information

It is important that the Warranty Card be completed and sent to Schmeiser. The warranty will not be valid until the information is on file at Schmeiser. If information not contained in this manual is needed, contact your Schmeiser dealer.

Serial Number

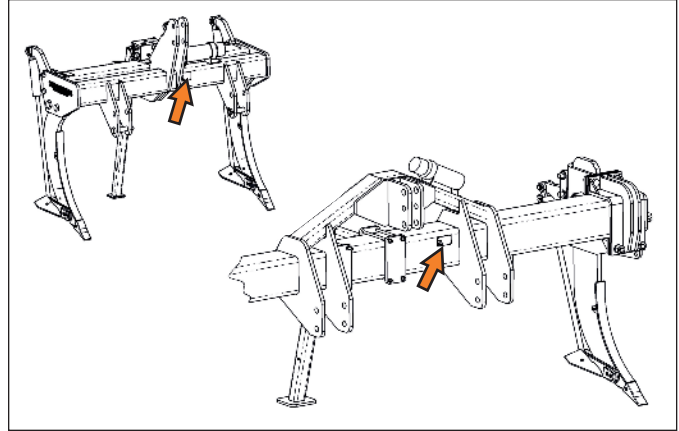

Serial No. _____

Model No. _____

Date Purchased. _____

Dealer Name. _____

Factory Contact Information

For questions not answered in this manual, if additional copies are required, or the manual is damaged, please contact your local dealer or:

T. G. Schmeiser Co., Inc.
P.O. Box 1392
Selma, CA 93662

Phone: (559) 268-8128
Fax: (559) 268-3279
E-mail: sales@tgschmeiser.com
Web: www.tgschmeiser.com

Additional copies of this manual can also be downloaded at www.tgschmeiser.com.

Dealer Contact Information

For replacement decals, questions, or to order parts, contact your dealer:

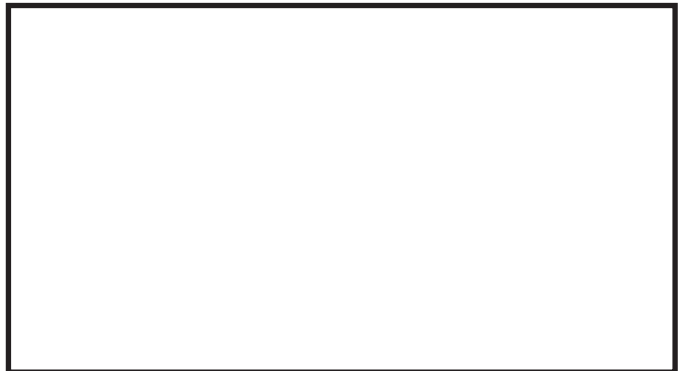

SAFETY

Carefully read and follow all safety precautions before operation. There are obvious and hidden potential hazards involved in the operation of this implement. Serious injury or death may occur unless care is taken to ensure the safety of both the operator and any other persons in the area. Avoid potential danger by taking extra time for thought and a more careful approach to the use of this implement.

Most work related accidents are caused by failure to observe basic safety rules or precautions. An accident can often be avoided by recognizing potentially hazardous situations before an accident occurs. As you assemble, operate, or maintain the unit, you must be alert to potential hazards. You should also have the necessary training, skills, and tools to perform any assembly or maintenance procedures.

Improper operation and maintenance of this unit could result in a dangerous situation that could cause injury or death. T.G. Schmeiser cannot anticipate every possible circumstance that might involve a potential hazard. The warnings in this manual and on the product are, therefore, not all-inclusive. If a method of operation not specifically recommended by us is used, you must satisfy yourself that it is safe for you and for others. You should also ensure that the unit will not be damaged or be made unsafe by the methods that you choose.

The information, specifications, and illustrations in this manual are based on the information that was available at the time this material was written and are subject to change without notice.

Safety Alert Symbols



This is the safety alert symbol. It is used to alert you to potential personal injury hazards.

Obey all safety messages that follow this symbol to avoid possible injury or death.

This manual contains DANGERS, SAFETY INSTRUCTIONS, CAUTIONS, IMPORTANT NOTICES, and NOTES which must be followed to prevent the possibility of improper service, damage to the equipment, personal injury, or death. The following key words call the readers attention to potential hazards.

Hazards are identified by the "Safety Alert Symbol" and followed by a signal word such as "DANGER", "WARNING", or "CAUTION".

DANGER

Indicates an imminently hazardous situation which, if not avoided, will result in death or serious injury. This signal word is limited to the most extreme situations.

WARNING

Indicates a potentially hazardous situation which, if not avoided, could result in death or serious injury.

CAUTION

Indicates a potentially hazardous situation which, if not avoided, may result in minor or moderate injury.

NOTICE

Indicates that equipment or property damage can result if instructions are not followed.

SAFETY INSTRUCTIONS

Safety instructions (or equivalent) signs indicate specific safety-related instructions or procedures.

Note: Contains additional information important to a procedure.

Safety Icons Nomenclature

This manual and the equipment has numerous safety icons.

These safety icons provide important operating instructions which alert you to potential personal injury hazards.

Personal Protection/Important Information

 READ THE MANUAL

 THINK SAFETY

 MAINTENANCE PROCEDURE

 WEIGHT RATING

 EYE PROTECTION

 HAND PROTECTION

 HEAD PROTECTION

 HEARING PROTECTION

 INSPECT EQUIPMENT

 OEM PARTS ONLY

 PLACE IN NEUTRAL

 PROTECTIVE SHOES

 REMOVE KEY

 DAMAGED HAZARD LABEL

 SLOW VEHICLE PLACARD

 SET PARKING BRAKE

 STOP ENGINE

 SUPPORT STAND USAGE

 USE PROPER TOOLS

 VISUALLY INSPECT

 USE ROPS

 USE CORRECT PARTS

Prohibited Actions

 DO NOT ALTER OR MODIFY

 DO NOT LEAVE OUT TOOLS

 DO NOT WELD

 NO ALCOHOL

 NO CHILDREN

 NO DRUGS

 NO PASSENGERS

 NO RIDERS

 NO BYSTANDERS

Hazard Avoidance

 BLOCK WHEELS

 CRUSHING HAZARD (body)

 CRUSHING HAZARD (foot)

 CRUSH HAZARD (rolling over)

 DEFECTIVE OR BROKEN PART

 FALLING HAZARD

 MAINTAIN SAFE DISTANCE

 OVERTURN HAZARD

 PINCH POINT HAZARD

 SAFETY ALERT SYMBOL

 SHARP OBJECT HAZARD

 ZERO PRESSURE

 COMPRESSED AIR HAZARD

 CRUSH HAZARD

 CRUSH HAZARD

 HIGH PRESSURE FLUID HAZARD

 HOT SURFACE HAZARD

 HEAVY OBJECT HAZARD

GENERAL SAFETY

WARNING



Read and Understand Manual

To prevent personal injury or even death, be sure you read and understand all of the instructions in this manual and other related OEM equipment manuals! This equipment is dangerous to children and persons unfamiliar with its operation. The operator should be a responsible adult familiar with farm machinery and trained in this equipment's operations. Do not allow persons to operate or maintain this unit until they have read this manual and have developed a thorough understanding of the safety precautions and how it works.

This unit was designed for a specific application. DO NOT modify or use this unit for any application other than that for which it was designed.

Units operated improperly or by untrained personnel can be dangerous!

NO PASSENGERS ALLOWED



Fall Hazard

Do not use this implement as a work platform. Do not stand on top of the unit at any time. Do not ride on the tractor or the implement or allow others to ride.



Crush Hazard (Rolling Over)

To prevent serious injury or death, before disconnecting, leaving the operator's seat, servicing, adjusting, repairing, or performing other work on the implement, ALWAYS:

1. Stop the tractor or towing vehicle.
2. Shut off the engine and remove the ignition key.
3. Set the brakes.
4. Make sure wheel cylinder transport lock is attached.
5. Relieve hydraulic fluid pressure.



Injury Hazard

Do not permit children to play on or around the unit.



Impaired Operator Hazard

Do not attempt to operate this unit under the influence of drugs or alcohol. Review the safety instructions with all users annually.



Pinch Point /Sharp Object Hazard

Do not place any body parts between moving and / or stationary parts. The weight of the implement will easily cause serious bodily injury.



Visually Inspect

Visually inspect the unit for any loose bolts, worn parts, or cracked welds, and make necessary repairs before using the unit.

Personal Protection Equipment

When working around or operating this unit, wear appropriate personal protective equipment. This list includes but is not limited to:



- A hard hat
- Protective shoes with slip resistant soles
- Protective goggles, glasses, or face shield
- Heavy gloves and protective clothing
- Ear muffs or plugs



Use Properly Rated Tools

To prevent serious injury: Use sufficient tools, jacks, and hoists that have the capacity for the job.



Rolling Hazard

To prevent serious injury, lock the wheels when performing assembly, maintenance, repairs, or when preparing for storage.

ASSEMBLY SAFETY

WARNING



Crush Hazard

Use support blocks or safety stands rated to support the load when assembling the unit or performing maintenance. Never work under equipment supported by hydraulics. Hydraulics can drop equipment instantly if controls are actuated even when power to the hydraulics is shut off.

TRANSPORT SAFETY



WARNING



Loss of Control

A minimum of 20% of the combined tractor and equipment weight should be on the front wheels to ensure adequate stability during transport and operation. To avoid serious injury or death from a loss of control accident, maintain 20% weight on the front wheels. Add front end weight if necessary.



Hitch and coupling on the towing vehicle must be rated equal to, or greater than, the unit's "gross vehicle weight rating" (GVWR).

SAFETY INSTRUCTIONS



When transporting, remember the implement may be wider than your tractor and extreme care must be taken to allow for safe clearance.



Be aware of physical surroundings and especially bystanders, particularly children, before moving the unit! This is particularly important with higher noise levels and quiet cabs, as you may not hear people shouting.

Avoid sudden uphill turns on steep slopes.

Always drive at a safe speed relative to local conditions, and ensure that your speed is low enough for an emergency stop to be safe and secure. Keep speed to a minimum.

Reduce speed prior to turns to avoid the risk of overturning.

Watch for overhead obstructions and side clearances while transporting.

Always operate equipment in a position to provide maximum visibility at all times. Make allowances for increased length and weight of the equipment when making turns, stopping, etc.

Highway and Transport Operations

SAFETY INSTRUCTIONS



When transporting the implement on public roads, use approved accessory lighting, flags, or other necessary warning devices to protect operators of other vehicles on the highway during daytime and nighttime transport. Various safety lights and devices are available from your dealer.



When transporting the unit on public roads, use flashing amber warning lights and a slow moving vehicle (SMV) identification emblem.

Make sure the SMV placard is clearly visible to vehicles approaching from the rear.

Some localities prohibit the use of flashing amber lights. Local laws should be checked for all highway lighting and marking requirements.

Be a safe and courteous driver. Always yield to oncoming traffic in all situations, including narrow bridges, intersections, etc. Plan your route to avoid heavy traffic.

Be observant of bridge load restrictions. Do not cross bridges rated lower than the gross weight at which you are operating.

When transporting the implement on rough or uneven surfaces, drive slowly to prevent bouncing and loss of contact of the front wheels and the ground.

OPERATION SAFETY



WARNING



Crush Hazard (Rolling Over)

Do not clean, lubricate, or make adjustments while the unit is moving.



Never allow inexperienced or untrained personnel to operate the implement or tractor without supervision.



Enter And Exit Tractor

To avoid being run over, do not enter or exit tractor when it is moving. Avoid serious injury or death, from contact with rotating tires, by entering or exiting tractor only when it is completely stopped.



Safe Distance

Keep all bystanders, especially children, away from the tractor and implement during operation.

Overturn Hazard



Pick the most level route possible when transporting across fields. Avoid the edges of ditches, gullies, or steep hillsides. Be especially careful when turning on slopes with the wheels down. Never turn uphill with the wheels down except at slow speed and a low rate of turn. Never transport or operate this machine on steep slopes.

Heavy Lifting Hazard



Single person lift could cause injury. Two persons required when moving or lifting heavy components.

SAFETY INSTRUCTIONS



Periodically clear the unit of brush, twigs, or other materials to prevent buildup of dry, combustible materials.



Visually check all fasteners for tightness or damage before and after operation. Repair immediately if required.

Tractor Requirements



WARNING



Tractor Owner/Operator Manual
Always refer to the tractor Operator's Manual to ensure compatibility and maximum safety.

Be familiar with the location, settings, and function of the tractor controls before using this equipment.

SAFETY INSTRUCTIONS

Do not use a tractor of more than the recommended HP to prevent damaging implement components.

Tractor Safety Devices

If transporting or operating the tractor and implement near a public roadway, the tractor must be equipped with proper warning lighting and a Slow Moving Vehicle (SMV) emblem, which are clearly visible from the rear of the unit. Lights and a SMV emblem must be attached directly to the implement if the visibility of the tractor warning signals is obscured.

Never operate the tractor PTO with the PTO master shield missing or in the raised position.

ROPS and Seat Belt

The tractor must be equipped with a Roll Over Protective Structure (ROPS) (tractor cab or roll-bar) and seat belt to protect the operator from falling off the tractor, especially during a roll-over where the driver could be crushed and killed.

Only operate the tractor with the ROPS in the raised position and seat belt fastened.



WARNING



Rollover Hazard

To avoid serious injury or death from falling off tractor, equipment runover, rollover, or crushing:

- 1) Use ROPS equipped tractor.
- 2) Keep ROPS locked in the UP position.
- 3) Only operate the equipment when seated in the tractor seat.
- 4) Always fasten seat belt when operating the tractor and Implement.

Connecting to Tractor



WARNING



Crush Hazard

Use care when attaching the unit to the tractor. Never place any part of your body under the tongue or hitch assembly. Do not allow anyone to stand between moving tractor and implement during hook-up operations.

Hydraulic Components Safety



WARNING



High-Pressure Fluid Hazard

Before applying pressure to the system, make sure all components are tight and that the hydraulic lines, hoses, fittings, and couplings are not damaged.



Hydraulic Pressure

This unit operates with hydraulic pressures of 2500 to 3000 psi (170 to 205 bars).



High-Pressure Separation Hazard

Replace any worn, cut, abraded, flattened, or crimped hoses.

High-Pressure Fluids



1. Check or tighten all connections BEFORE pressurizing system.



2. Release all pressure before removing hoses and/or valves by:

- a. Stopping engine.
- b. Holding hydraulic control levers in float or neutral position.



3. DO NOT use your bare hand to check for potential leaks. Always use a board or cardboard when checking for a leak.

Escaping hydraulic fluid under pressure, even a pinhole size leak, can penetrate body tissue, causing serious injury and possible death. If fluid is injected into your skin, it must be treated immediately by a doctor familiar with this type of injury.



Wear proper hand and eye protection when searching for a high-pressure hydraulic leak.

Use a piece of wood or cardboard as a backstop instead of hands to identify and isolate a leak.

If injured by a concentrated high-pressure stream of hydraulic fluid, seek medical attention immediately. Without immediate medical treatment, serious infection or toxic reaction can develop if hydraulic fluid penetrates the surface of the skin.

Trapped Air Hazard



When installing, replacing, or repairing hydraulic system cylinders or parts, make sure that the entire system is charged and free of air before resuming operations. Failure to bleed the system of all air can result in improper machine operation, causing severe injury.

Zero Pressure



Relieve pressure from the hydraulic system before servicing or disconnecting from the tractor.

High-Pressure Hazard



Do not make any temporary repairs to the hydraulic lines, fittings, or hoses using tape, clamps, or cement. The hydraulic system operates under extremely high pressure and temporary repairs may fail suddenly and create a hazardous/dangerous situation.

Hot Surface Hazard



Keep away from valve. The valve assembly can reach temperature of up to 180°F. Contact with skin may cause burns.

CAUTION



Explosive Separation Hazard

Be sure all hydraulic pressure is relieved before disconnecting hydraulic lines or fittings between implement and the tractor hydraulic system.

NOTICE

Make sure components in the hydraulic system are kept clean and in good working condition.

MAINTENANCE SAFETY

WARNING



Use Properly Rated Tools

Use sufficient tools, jacks, and hoists that have the capacity for the job.



Crush Hazard

Use support blocks or safety stands rated to support the load when performing maintenance.

SAFETY INSTRUCTIONS

Follow all operating, maintenance, and safety instructions found in this manual.



Understand the service procedure before performing the work. Keep area clean and dry.



Keep all parts in good condition and properly installed. Fix damage immediately. Replace worn or broken parts.



Do not leave tools lying on the unit.



Do not modify unit or safety devices. Do not weld on the unit. Unauthorized modifications may impair its function and safety.

If equipment has been altered in any way from the original design, the manufacturer does not accept any liability for injury or warranty.



Never replace hex bolts with less than Grade 5 bolts unless otherwise specified. In locations where Grade 8 bolts are used, Grade 8 replacements are required.



Where replacement parts are necessary for periodic maintenance and servicing, genuine factory replacement parts must be used to restore the unit to original specifications.

The manufacturer will not accept responsibility for damages as a result of the use of unapproved parts.

Bolt Torque Requirements

It is extremely important to apply and maintain proper torque on all bolts. Use a torque wrench to assure the proper amount of torque is being applied to the fastener. Start all bolts or nuts by hand to prevent cross threading.

Torque figures indicated in the chart are used for non-greased or non-oiled threads unless otherwise specified.

Therefore, do not grease or oil bolts or cap screws unless otherwise specified in this manual. When using locking elements, increase torque values by 5%.

The chart gives correct torque values for various bolts and cap screws. Tighten all bolts to the torques specified in the chart unless otherwise noted. Check tightness of bolts periodically, using the bolt torque chart as a guide. Always replace hardware with the same Grade bolt.

⚠️ WARNING



Equipment Failure

The torque value for bolts and cap screws are identified by their head markings. Replacing higher "Grade" bolts (Grade 5) with lower Grade bolts will lead to equipment failure and can result in injury or death. Always use replacement bolts with the same Grade markings as the removed bolt.

Bolt Diameter	Bolt Torque Specifications			
	Grade 5		Grade 8	
	N·m	ft.lbs.	N·m	ft.lbs.
1/4"	12	9	17	12
5/16"	25	19	36	27
3/8"	45	33	63	45
7/16"	72	53	100	75
1/2"	110	80	155	115
9/16"	155	115	220	165
5/8"	215	158	305	220
3/4"	390	290	540	398
7/8"	570	420	880	650
1"	850	630	1320	970

Welding Repairs



Before performing any type of welding repair to the implement, contact T.G. Schmeiser Co., Inc. for approval. Repair welding must be done with care and with procedures that may be beyond the capabilities of the ordinary welder.

⚠️ WARNING



Personal Injury Hazard

Repairs or modifications to the implement can result in serious injury or death should these repairs fail.

NOTICE

Anyone performing a welding repair should be certified in accordance to the American Welding Society (AWS)

STORAGE SAFETY

⚠️ WARNING



Hazard And Information Signs

Replace any missing or hard-to-read safety signs. Safety sign placement and part numbers can be found on pages 12-13 of this manual.



Damaged Parts Hazard

Do not use this unit if it is in need of repair. If you believe the unit has a defect which could cause damage, injury, or death, you should immediately stop using the unit.

SAFETY INSTRUCTIONS



Store the implement in an area away from human activity.



Do not permit children to play on or around the stored unit at any time.



When using compressed air to clean implement, wear safety glasses.

DISPOSAL OF EQUIPMENT AT END OF USEFUL LIFE

The T. G. Schmeiser implement has been designed for the specific purpose of conditioning the ground in agricultural applications. When this unit is no longer capable of doing its designed purpose, it should be dismantled and scrapped. Do not use any materials or components from this unit for any other purpose.

SAFETY SIGNS AND DECALS

SAFETY INSTRUCTIONS



Replace all worn or damaged safety and instruction decals.

- It is the responsibility of the customer to know the marking requirements of the local highway authorities and to comply with the regulations.
- Keep safety signs clean and legible at all times. Replace safety signs that are missing or have become illegible.
- Do not paint over, remove, or deface any safety signs or instructional decals on your equipment.
- Observe all safety signs and follow the instructions on them.
- When parts that display a safety sign are replaced, the replacement part should display the same sign.
- Make sure the safety signs and other instructional decals are legible and attached to the unit before use.
- Safety signs are available from your Distributor, Dealer Parts Department, or the factory.
- Use care when washing or cleaning the unit not to remove or damage the labels.
- Locations for the labels and replacement part numbers are shown in this section.

Safety Signs Placement

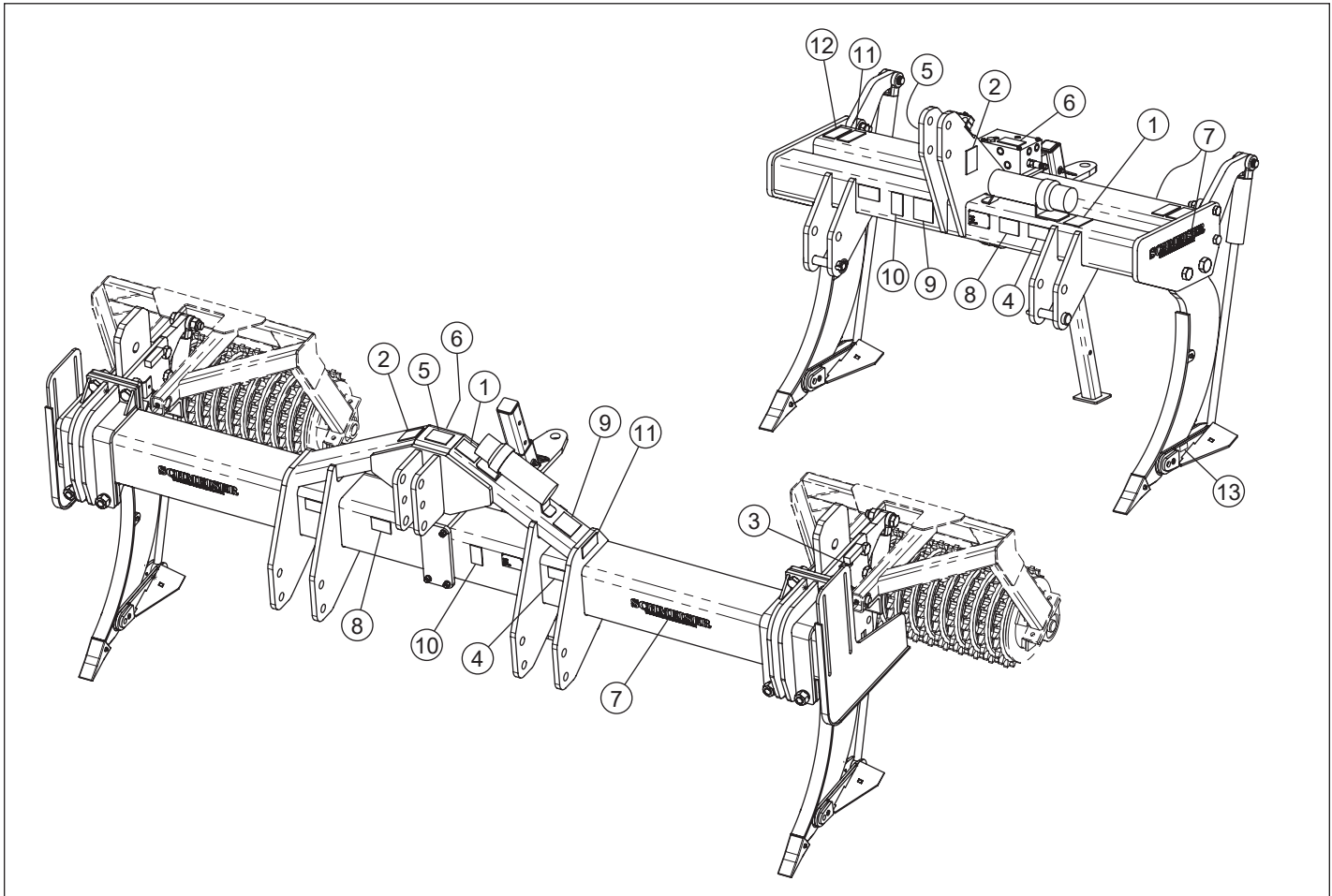

Safety Signs for Mid-Row Ripper

Item	Part Number	Description	Qty.
1	D48X038RTM	Read the Manual	1
2	D48X038CRR	Crush / Rollover Hazard	1
3	D28X048SCE	Sharp Cutting Edge	2
4	D28X048PPT	Pinch Point	2
5	D48X064HPF	High Pressure Fluids	1
6	D28X048HSF	Hot Surface Caution	1
7	D32X208TGS	Schmeiser (13")	4
8	D32X048RBC	Made in the USA	1
9	D48X48QR	Scan to Access Online Manual	1
10	DFEMALOGO1	FEMA	1
11	D48X080RW2	Attention Ripper Shanks	2
12	D48X080RW1	Attention Shear Bolt (Mini only)	2
13	D16X026GRS	Grease Decal	2
		Grease Decals for Till An' Pak	8

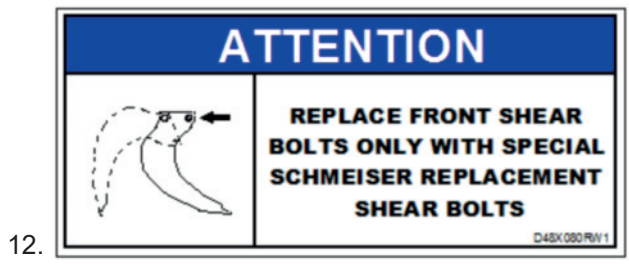
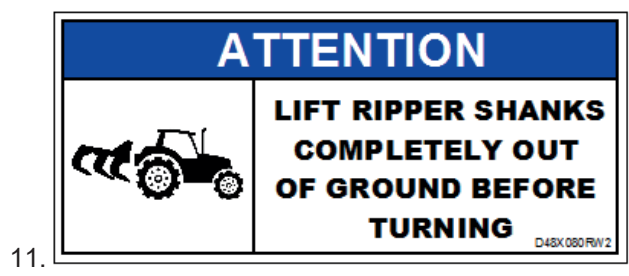
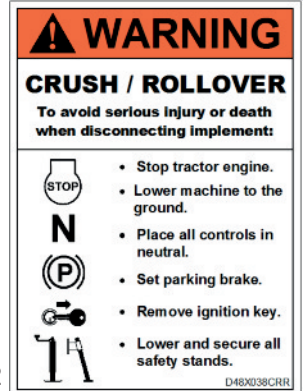
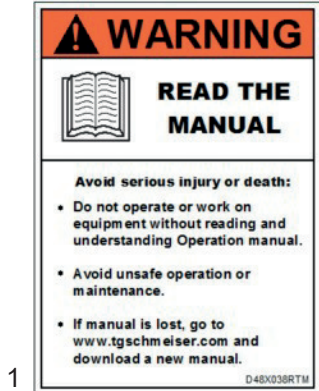

SPECIFICATIONS

Mini Mid-Row Ripper™

Model #	Unit Size	Overall Width	Frame Width	Shank Spacing	Weight
ASW32	3'	37-3/4"	36-1/4"	33-3/4"	690 LBS
ASW32	4'	48-3/4"	47-1/4"	44-3/4"	730 LBS
ASW32	5'	59-3/4"	58-1/4"	55-3/4"	775 LBS

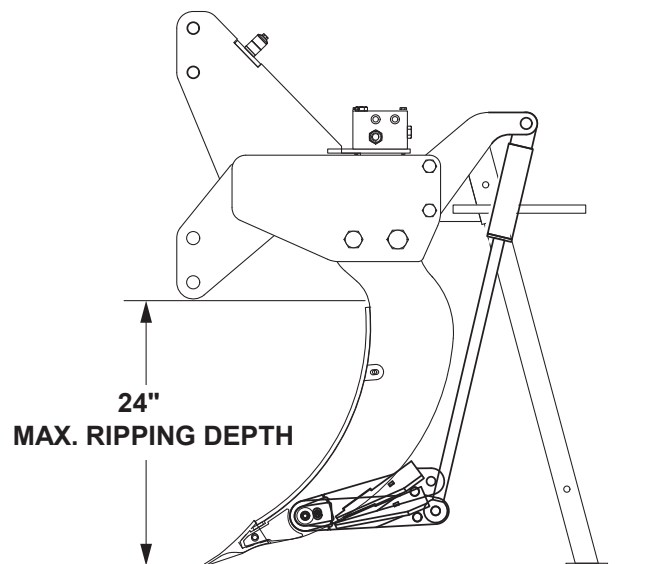
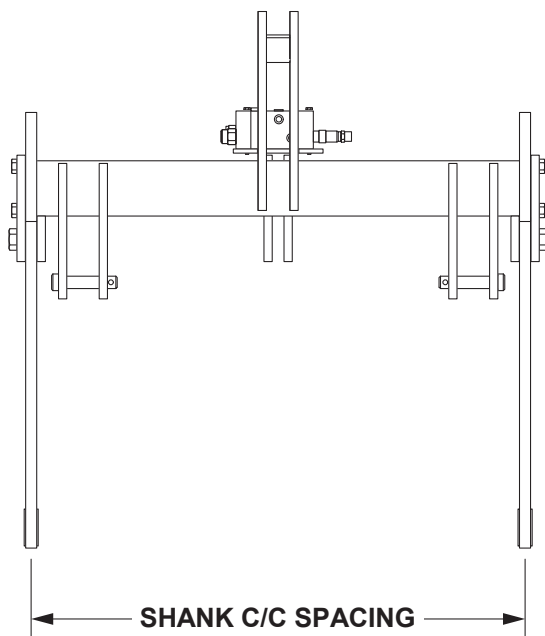
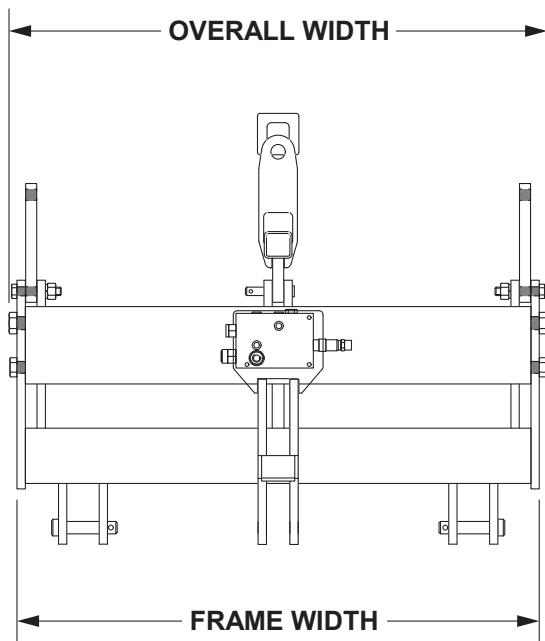

SPECIFICATIONS

HD Mid-Row Ripper™

Model #	Unit Size	Overall Width	Width W / TP	Min. Shank Spacing	Max. Shank Spacing	Weight
ASW52060	5'	65-1/8"	86-1/8"	54"	54"	1265 LBS
ASW52072	6'	74-1/8"	96-1/8"	54"	64"	1300 LBS
ASW52084	7'	86-1/8"	108-1/8"	54"	76"	1350 LBS
ASW52096	8'	98-1/8"	120-1/8"	54"	88"	1400 LBS
ASW52120	10'	122-1/8"	144-1/8"	54"	112"	1500 LBS
ASW52132	11'	134-1/8"	156-1/8"	66"	124"	1590 LBS
ASW52144	12'	146-1/8"	168-1/8"	66"	136"	1640 LBS

NOTE: EXTENSIONS ADD 36" TO MAXIMUM SHANK SPACING

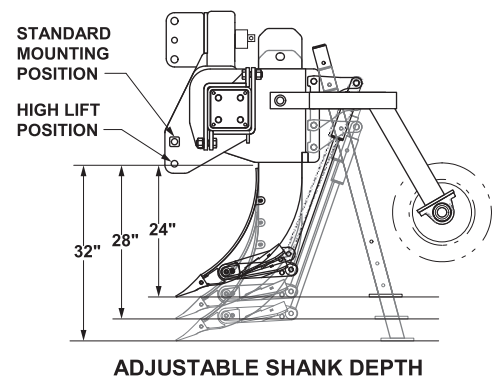
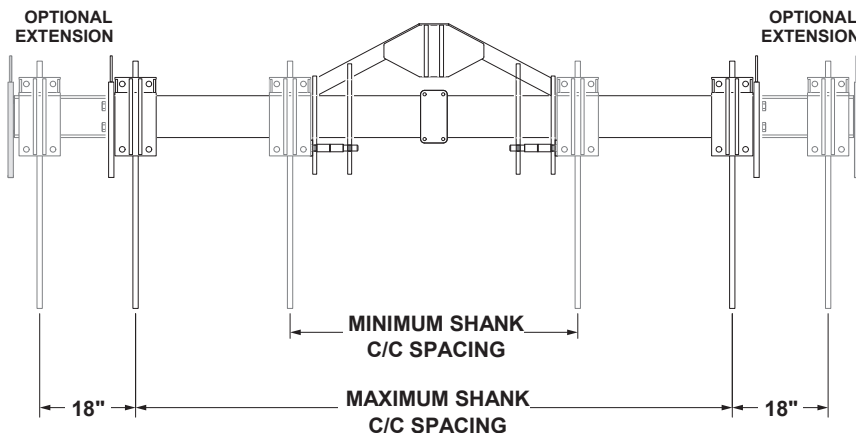
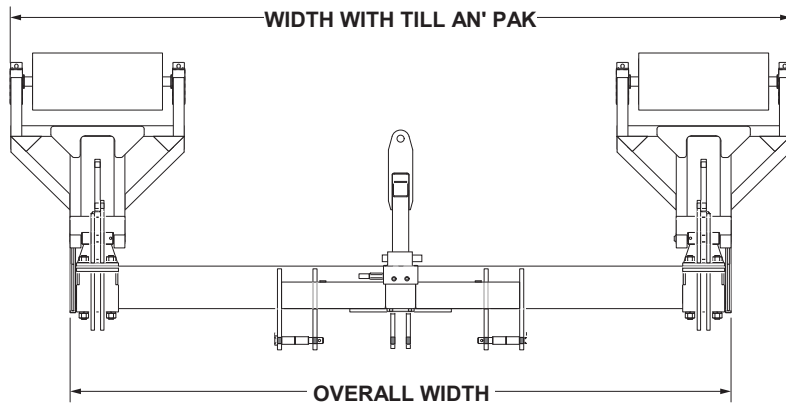

SAFETY LIGHTING AND MARKING

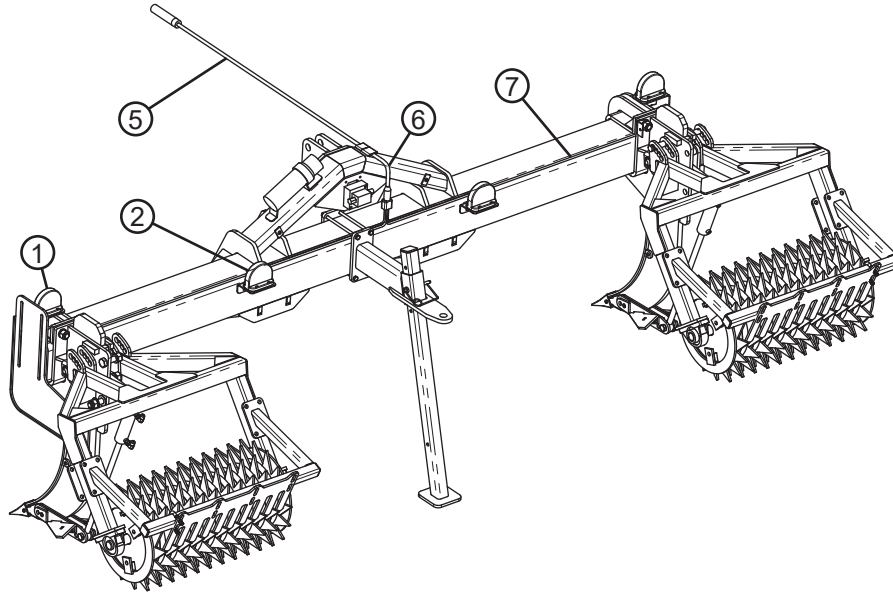

SAFETY LIGHTING WIRING DIAGRAM

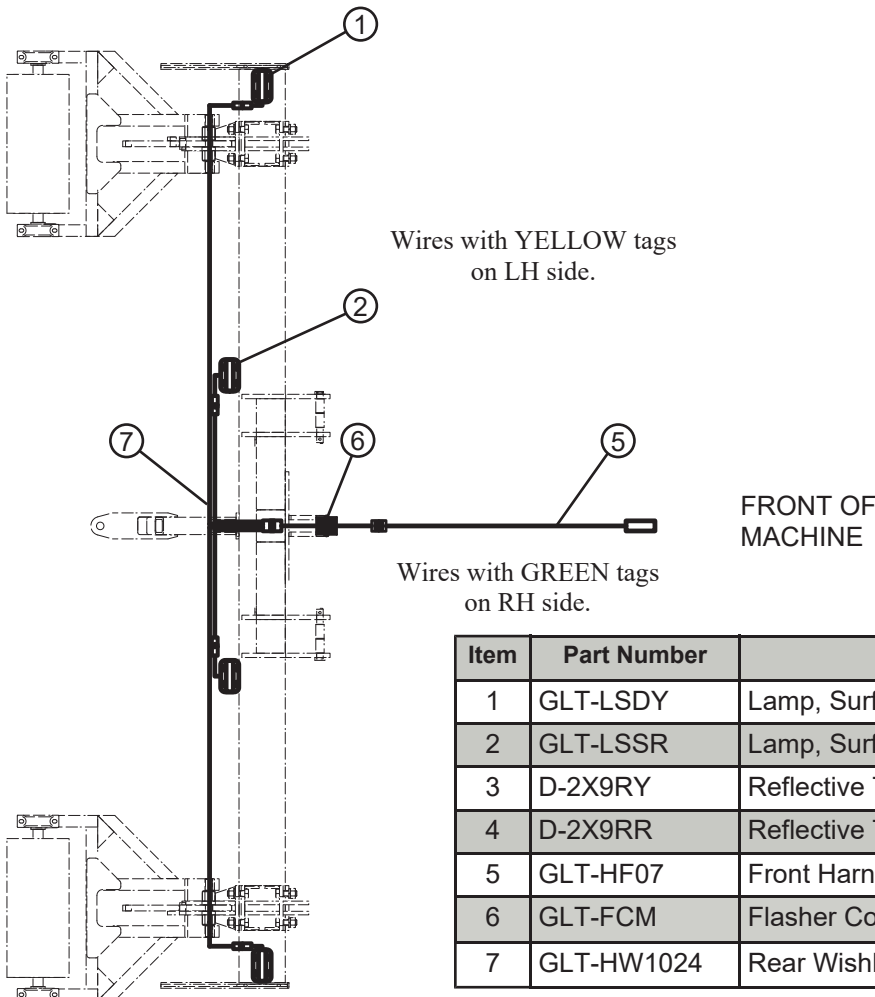

Item	Part Number	Description	Q'ty
1	GLT-LSDY	Lamp, Surface Mount Double Yellow (Optional)	2
2	GLT-LSSR	Lamp, Surface Mount Single Red (Optional)	2
3	D-2X9RY	Reflective Tape, Yellow	8
4	D-2X9RR	Reflective Tape, Red	2
5	GLT-HF07	Front Harness, 7 Ft. Long	1
6	GLT-FCM	Flasher Control Module	1
7	GLT-HW1024	Rear Wishbone Harness 10 Ft.-24 Ft.	1

SPECIFICATIONS

Tractor Requirements



The tractor used to operate the Mid-Row Ripper™ must have sufficient distribution of weight and horsepower to operate the unit effectively at recommended ground speeds between 2.5 and 4.5 MPH. We recommend a four wheel drive tractor, with well distributed weights.

Use the chart below to select the tractor horsepower appropriate for your Mid-Row Ripper™. Do not use a tractor of more than the recommended HP to prevent damaging Mid-Row Ripper™ components.

A minimum of 20% of the combined tractor and equipment weight should be on the front wheels to ensure adequate stability during transport and operation. Add front end weight as needed to maintain 20% weight on the front axle.

Horse Power Requirements

Model # / Size	Recommended HP
ASW32036 / 3' MINI	100 - 125
ASW32048 / 4' MINI	100 - 125
ASW32060 / 5' MINI	100 - 125
ASW52072 / 6' HD	110 - 135
ASW52084 / 7' HD	110 - 135
ASW52096 / 8' HD	110 - 135
ASW52120 / 10' HD	110 - 135
ASW52132 / 11' HD	110 - 135
ASW52144 / 12' HD	110 - 135

Hydraulic Requirements

The Mid-Row Ripper™ functions with both Open Center and Closed Center hydraulics at a working pressure of 1400 to 1800 PSI.

The tractor requires flow control and detent for continuous operation.

FLOW RATE:

- For Mini models - 4 to 20 GPM (optimal is 9 GPM).
- For HD models - 1 to 8 GPM (optimal is 4 GPM).

NOTE: Some tractors are equipped with smaller hydraulic reservoir systems. This may create a heat issue. Additional cooling attachment may be required.

Always review the “controls” section of the tractor Operator’s Manual to be familiar with the location, settings, and function of the tractor controls. Be familiar with all controls before using this equipment.

3-Point Hitch

The Mid-Row Rippers™ are designed to be mounted on the following tractor categories:

- 3' MINI: CAT II 3-Point.
- 4'-5' MINI: CAT II 3-Point, CAT II Quick Hitch.
- 5'-12' HD: CAT II, CAT III N, CAT III 3-Point, CAT II Quick Hitch.

Refer to the tractor Operator’s Manual for the category of the tractor being used. If the hitch does not conform to ASAE CAT II / III dimensions, the Mid-Row Ripper™ may not fit or raise properly. Consult an authorized dealer for possible modification procedures to mount non-conforming hitches. Depending on the hitch category, certain size pins are used to attach the implement to the tractor. CAT II hitches require 1-1/8” dia. lower and 1” dia. upper hitch pins. CAT III hitches require 1-7/16” dia. lower and 1-1/4” dia. upper hitch pins.

Install the lift arm stabilizer or shorten the stop chains to place the arms into the non-sway configuration. Refer to the tractor manual for details.

OPERATION



WARNING



Understand Safety Procedures!

Read and understand all safety procedures described in this manual before performing any work on or around the implement.

Attaching to Tractor

Make sure the unit is resting on the ground with safety stand securely installed before attaching the unit to the tractor.

1. Check oil level and condition in tractor reservoir. Oil must be clean and reservoir full.

NOTE: Some tractors are equipped with smaller hydraulic reservoir systems. This may create a heat issue. Additional cooling attachment may be required.

2. Use caution when connecting the Mid-Row Ripper™ to the tractor. The Mid-Row Ripper™ should be securely resting on the ground with the rear Safety Stand lowered and secured. Keep hands and feet from under the Mid-Row Ripper™ and clear of pinch points between the tractor drawbar and the Ripper hitch.

NOTE: Shorten or remove the tractor draw bar to avoid interference when raising and lowering the Mid-Row Ripper™.

3. Remove the lynch pins and lift pins.
4. Board the tractor and start the engine. Position the tractor with the 3-point lift arms positioned at the same height and aligned with the Mid-Row Ripper™ hitch pin holes.

Note: Set the 3-point lift control to "Position Control" so that the lift arms maintain a constant height when attaching the Mid-Row Ripper™. See the tractor Operator's Manual for correct settings when attaching 3-point equipment.

5. Turn off the tractor engine and dismount.
6. Insert the hitch pin through the lift arm and lug holes and install the lynch pin.
7. Walk around to the opposite side and repeat the procedure for the remaining lift arm and hitch pin.
8. Extend or retract the 3-point top link to align its end hole with the hole of the Mid-Row Ripper's™ top link. Insert the top link hitch pin and insert the lynch pin into the hitch pin.
9. Return to the tractor and slowly raise the 3-point lift arms fully up and down to make sure the Mid-Row Ripper™ does not make contact with the tractor tire, draw bar, or any other equipment on the tractor.

NOTE: Move or remove the draw bar if it interferes with the implement.

10. Adjust any lower link check chains, guide blocks, or sway blocks to prevent the Mid-Row Ripper™ from swaying side-to-side.
11. Remove safety clip and securing pin on rear Safety Stand, raise Stand to storage position, and reinstall securing pin and safety clip.

Note: Rear Safety Stand should always stay with unit.

Connecting to Tractor Hydraulics

1. Clean lead hose tips from dirt and debris.
2. Connect lead hose from the Mid-Row Ripper™ valve "P" port to detent port on tractor.
3. Connect remaining lead hose from the Mid-Row Ripper™ valve "T" port directly to oil reservoir (recommended), or to return port on tractor.

See diagram below for details.

NOTE: Not all tractors are equipped to connect hose directly to tank. Additional plumbing may be required.

NOTE: If lead hoses are reversed, detent may not function.

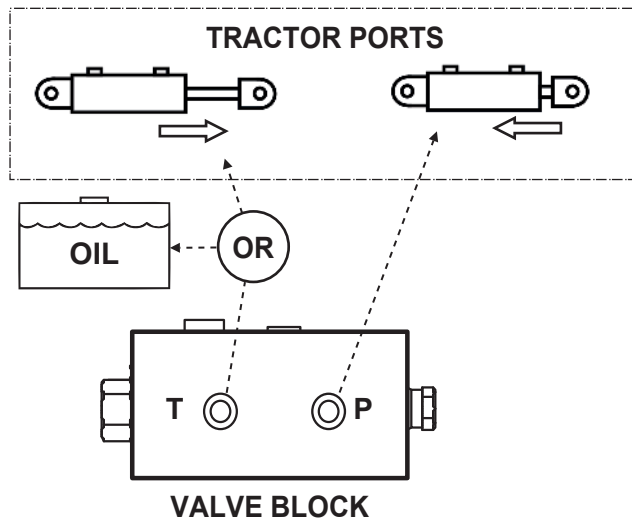

Setting the Mid Row Ripper™





Properly setting the Mid-Row Ripper™ is essential for efficient and safe operation. A properly set Mid-Row Ripper™ will consistently achieve the desired results.

NOTE: The Mid-Row Ripper™ must be hitched to the tractor and raised off the ground to make the following adjustments.



Initial Setup Checklist

It is important for both personal safety and to maintain the mechanical condition of the Mid-Row Ripper™ that this checklist is followed.

Location	Task
	Make sure the Mid-Row Ripper™ is properly mounted to the 3-point hitch. Refer to “Attaching to Tractor” on page 16.
	Make sure all hardware is properly installed and tightened. Always use proper tools. Refer to “Maintenance Schedule” on page 25.
	Check the condition of the shanks, shins, wings and points. Refer to “Ground Engaging Components” on page 24.
	Check the Mid-Row Ripper™ valve, cylinders, hoses and fittings. Inspect for leaks. Refer to page 16.
	Check the Mid Row Ripper setup. Adjust if needed. Refer to pages 18-19 for proper shank adjustment.

1. Use the adjustment on the tractor 3-point hitch lift arm to level the Mid-Row Ripper™ from side-to-side.
2. Adjust the top link to level the Mid-Row Ripper™ from front to back.
3. Turn off tractor draft control. Pulling loads may not properly correspond with tractor hitch system.

NOTE: The operating angle of the Mid-Row Ripper™ is crucial to performance. A level running tool bar adjusted at full operating depth is the proper and optimum orientation.

A high angle, where the tool bar is rolled forward (top link too short), will have less soil lift, be harder to pull,

but faster to achieve depth. It can cause shank tip breakage, fast tip wear, and high wing wear on top of wings.

A low angle, where the tool bar is rolled backward (top link too long), will have more soil lift, be easier to pull, but slower to achieve depth. It can cause wear on bottom of shanks, wear on wing mounting plates where cylinders attach, and high wear on bottom of wings.

NOTICE

All units come with hydraulic hoses installed, and valves tested and factory preset.

Attempting to adjust or recalibrate valve can result in equipment damage.

Contact factory for proper calibration procedures.

Adjusting HD Mid Row Ripper™ Shanks

⚠ WARNING



Heavy Lifting Hazard

When adjusting or replacing shanks, single person lift could cause injury. Two persons required when moving or lifting.

The HD Mid-Row Ripper™ is a versatile implement that can be configured for a variety of field conditions. For optimal performance, it is recommended that the shanks be calibrated for each type of crop and row spacing. The HD Mid-Row Ripper™ is designed to adjust both the ripping depth and shank spacing.

Adjusting Shank Depth

The HD Mid-Row Ripper™ comes from the factory with the shanks set to a ripping depth of 24". To increase ripping depth from 24" to 28", or from 28" to 32", follow instruction below:

Note: When lowering shank, always reposition Cylinder Anchor first, move shank second. When raising shank, always reposition shank first, move Cylinder Anchor second.

If performed in this order, there is no need to disconnect the hoses.

1. Ensure that unit is clean and free of debris.
2. Perform adjustments on firm, level surface.
3. Attach Mid-Row Ripper™ to Tractor 3 point hitch. Refer to “Attaching to Tractor” on page 17.

4. Ensure that Safety Stand is lowered and secured in the 24" depth position.
5. Remove 1" x 3" cap screws, lock washers and hex nuts securing Cylinder Anchors.
6. Move Cylinder Anchors one hole position (down 4") and reinstall. Tighten fasteners.
7. Using tractor 3 point control, raise unit up slightly to remove load from Shank Mount Pins.
8. If optional Till An' Pak™ rollers are installed, support Till An' Pak™ with fork lift.
9. Remove 3/8" x 3" cap screw, lock washer and hex nut securing Shank Mount Pin.
10. Remove Shank Mount Pin.
11. Remove optional Till An' Pak™ roller with forklift.
12. Repeat steps 8 thru 11 for shank on other side.
13. Using tractor 3 point control, raise Main Frame one shank hole position (up 4").
14. Using forklift, reposition optional Till An' Pak™ to line up holes with shank and pocket.
15. Install Shank Mount Pin and 3/8" x 3" cap screw, lock washer and hex nut. Tighten fasteners.
16. Repeat steps 14 and 15 for shank (and Till An' Pak) on other side.
17. Lower and secure Safety Stand and Side Dirt Guards to new corresponding shank depth.

If optional rear rollers are installed (either Till An' Pak™ or Down Pressure), ripping depth can be further decreased by setting depth gauge pin to desired position. - See pages 22-23 for details.

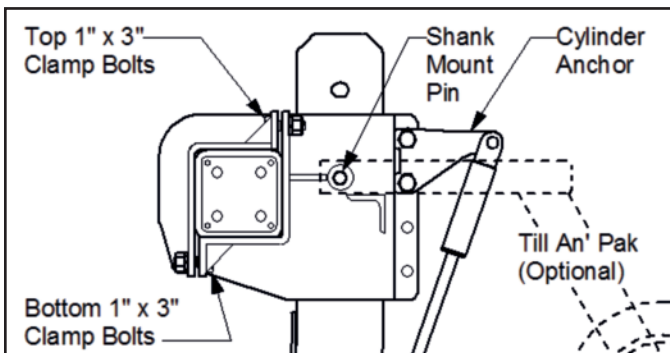

Adjusting Shank Spacing

NOTE: If equipped with optional Till An' Pak™ rollers, remove Till An' Paks™ with fork lift prior to adjusting shank spacing.

1. Ensure that unit is clean and free of debris.
2. Perform adjustments on firm, level surface.
3. Attach Mid-Row Ripper™ to Tractor 3 point hitch. Refer to "Attaching to Tractor" on page 17.
4. Ensure that Safety Stand is lowered and secured in the corresponding shank depth position.
5. Loosen bottom 1" x 3" clamp bolts.
6. Loosen top 1" x 3" clamp bolts until clamp is about 1/8" away from 8" x 8" toolbar.
7. Using two people, rock shank forward and back and slowly walk shank into desired position.
8. It is recommended to use a pry bar and/or lubricant to assist in repositioning shank.
9. Tighten clamp bolts, alternating from top bolt to diagonal bottom, to ensure even clamping on tool bar.
10. If necessary, loop and tie excess hydraulic hose on top side of tool bar to prevent equipment damage.
11. Repeat steps 5 thru 10 for shank on opposite side.

NOTE: Ensure that both shanks are positioned the same distance from the center of the unit. Uneven shank placement can result in poor tractor performance.

Implement Break-In

Although there are no operational restrictions on the Mid-Row Ripper™ when used for the first time, it is recommended that the following mechanical items be checked:

- After 1/2 hour of operation:
 - a. Check all fasteners and tighten if necessary.
 - b. Make sure the hydraulic valve, cylinders, hoses and fittings are in good condition.
 - c. Make sure that the shanks, shin guards, wing assemblies and points are in good condition.



- After 10 hours of operation:
 - a. Go to the normal servicing and maintenance schedule, as defined in the Maintenance Section.

General Operating Instructions

1. Familiarize yourself with the Operation and Parts Manual, and make sure the Mid-Row Ripper™ is properly attached to the tractor before beginning work. Inspect the condition of the shanks, points, wings, cylinders, valve and the overall Mid-Row Ripper™ for potential problems or damage. Do not use the Mid-Row Ripper™ if it needs repairs of any type.
2. Clear the area of bystanders, especially small children. Make sure that you can clearly see and identify passersby, steep slopes, ditches, drop-offs, power lines, debris, and foreign objects. If you are unable to clearly see these type of items, discontinue operating the Mid-Row Ripper™.
3. Know the location of all underground cables, pipelines, and other hazards in the area. Also make certain that all irrigation heads, utility outlets, and other obstacles are properly marked.
4. Watch for low hanging limbs, power lines, and other overhead obstacles while you are operating. Use care to avoid hitting these items.
5. Do not operate the Mid-Row Ripper™, or drive the tractor into material that is burning, or areas that recently burnt and may contain hot spots. Tire damage can occur when driving over hot material. Oil and grease on the tractor and Mid-Row Ripper™ could ignite, resulting in equipment destruction.
6. Turn on tractor hydraulics and slowly increase engine RPM to PTO speed. (Refer to Tractor Operator's Manual for proper setting).
7. Adjust Flow Rate.
 - Raise engine RPM to recommended PTO speed.
 - Turn flow control knob on the tractor all the way down to minimum setting.
 - Slowly increase oil flow until shank wings start moving approximately one cycle per second (about 9 GPM for Mini models, about 4 GPM for HD models).
8. Enter row to conduct ripping operation and place Mid-Row Ripper™ shank tips even with end posts.
9. Lower 3-Point control lever to depth setting and

proceed forward at a speed of no less than 2.5 MPH and no more than 4.5 MPH (optimal speed is 3.5 MPH). The Mid-Row Ripper™ should immediately begin burying shanks in the ground, allowing soil to flow around them.

NOTE: For tractors under 90 HP, start ripping prior to engaging hydraulics. Once shanks are buried in the ground, start hydraulics.

10. Once the Mid-Row Ripper™ is at the desired ripping depth on level ground, stop the tractor, turn off the engine and dismount. Adjust the top link so the tool bar and top link are level with the ground.

NOTE: If necessary, lower or raise Side Dirt Guards to prevent dirt from spilling onto berms.

11. If hard pulling is encountered, raise implement in small increments before excessive wheel spin is encountered. Excessive wheel spin lowers the tractor and implement considerably.

NOTE: If there is excessive trash and root build up on shanks, reversing unit slightly while lifting out of the ground may help clean shanks.

12. Exit row by lifting the Mid-Row Ripper™ prior to passing the end post, but not so early as to neglect the final row.
13. Lift the Mid-Row Ripper™ shanks completely out of the ground before turning. Failure to do so can result in equipment damage.
14. Slow the tractor when making turns. Remember that the Mid-Row Ripper™ will swing wide of the tractor when turning.
15. Always operate safely and follow all the instructions in this manual.

Operating Recommendations

- Shank position is vital for optimal performance. Running shanks too close to plants may cause damage to root system. T.G. Schmeiser Co., Inc. shall have no obligation or liability for unintended root damage.
- The objective is to remove soil compaction near the root zone without excessive root pruning, (shank roughly 18" - 30" from trunk in vineyards, 36" - 48" from trunk in orchards). Field conditions can vary greatly. Check with your crop advisor for suggested shank depth and spacing. We recommend that shank

position be tested and adjusted accordingly for optimal results. Refer to page 19 for adjustment procedure.

- It is recommended to rip every other row per season.
- To provide the best results for breakout and finish, we recommend ripping when soil is damp, but not wet. Ripping in dry conditions is harder to pull and can result in reduced fracture, larger clods (both above and below surface), and uneven finish.
- Running a Till An' Pak™ directly behind the unit will help break down clods, firm, level, and improve finish.
- Running a Down Pressure Roller behind the shanks is effective in breaking down large clods in severe conditions.

Detaching From Tractor

1. Move the Mid-Row Ripper™ to a level storage location. Park the tractor, place the transmission in park or neutral, and apply the parking brake. Lower the Mid-Row Ripper™, shut down the engine, and remove the key before exiting the tractor.
2. Make sure the Mid-Row Ripper™ is resting securely on the ground or blocks before attempting to disconnect it from the tractor. Use extreme care to keep feet and hands from under the Mid-Row Ripper™ and clear of any pinch points caused by the tractor hitch arms and Mid-Row Ripper™ hitch pins.
3. Lower and secure safety stand. Make sure the weight is distributed evenly between all supports.
4. Disconnect hydraulic hoses from the tractor. Coil the hoses and store them on top of implement.
5. Extend or retract the tractor 3-point hitch top link to remove tension on the top link hitch pin. When the pin is loose and easy to rotate, remove the pin from the Mid-Row Ripper™.
5. Disconnect the lift arms and drive the tractor away from the Mid-Row Ripper™.

Rear Rollers (Optional Equipment)

The rear rollers provide many additional benefits.

- They break down dirt clods left behind by shanks.
- They level and firm the soil.
- Rollers are lifted off the ground when turning.

Rollers can be set to float freely or gauge.

- Gauging system increases downward pressure where the roller teeth penetrate the ground.
- Quick pin adjustment allows rollers to gauge at shallower depths.
- Gauging provides additional stability while ripping.

Till An' Pak™ Rear Rollers

The rear ring rollers can be used to break dirt clods left behind by shanks and gently pack, level and firm the soil.

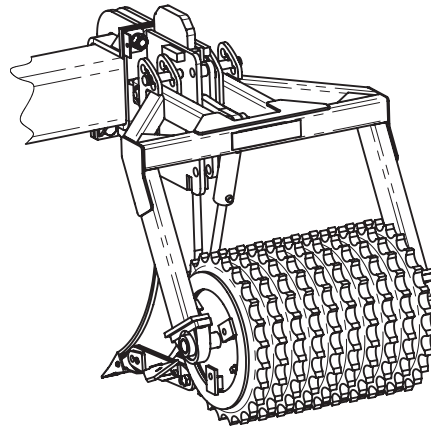

Down Pressure Rear Rollers with Steel Star Rings

The rear down pressure rollers can be used to break down large clods in more severe applications.

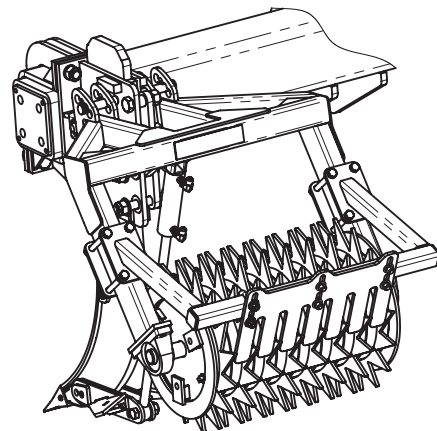

NOTICE

Setting gauging depth at the shallowest position and then attempting to rip deeper than setting may damage equipment.

In order to adjust the depth, move adjustment gauging pin to the desired setting. See table below for all gauging depths settings.

Gauging Adjustment

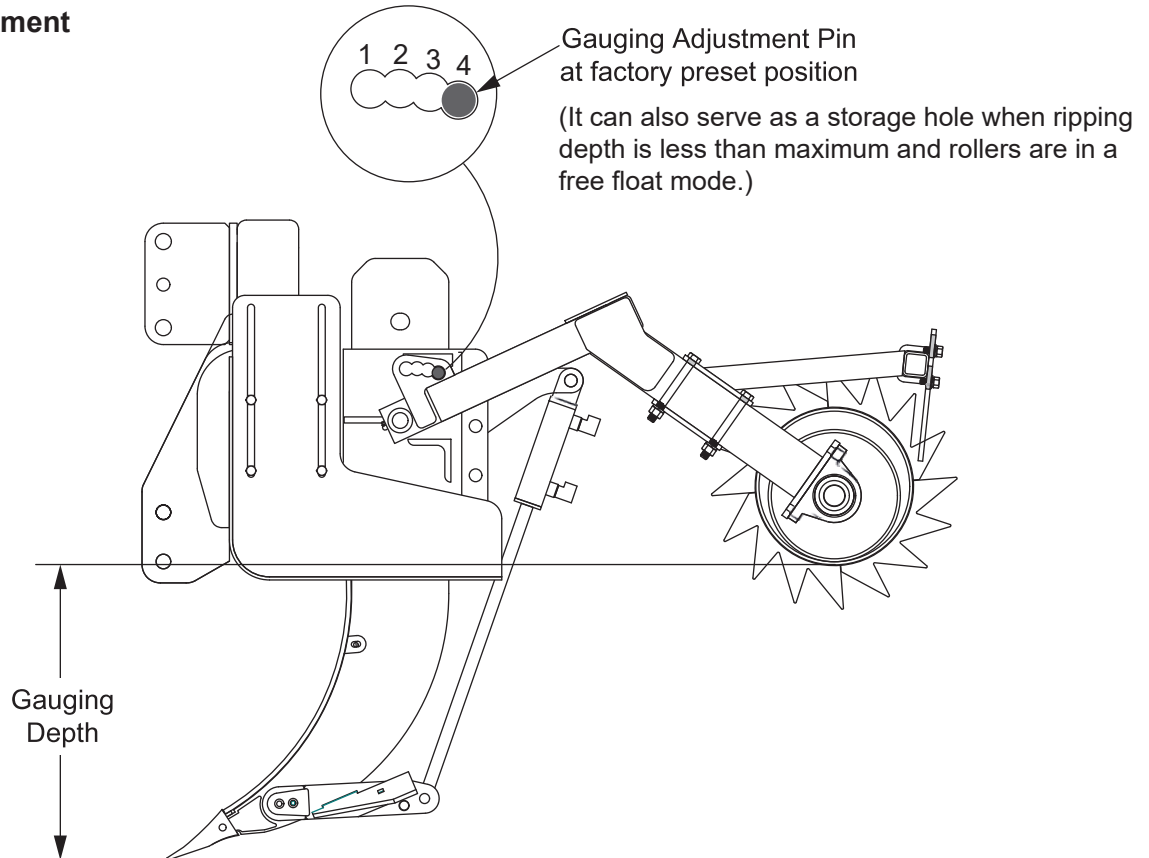

Rear Rollers Gauging Depths Table

Adjustment Pin Position	Shank Position (see p. 19 for adjustment instructions)		
4 (factory preset)	24"	28"	32"
3	21.5"	25.5"	29.5"
2	17.5"	21.5"	25.5"
1	14"	18"	22"

MAINTENANCE

WARNING



Understand Safety Procedures!

Read and understand all safety procedures described in this manual before performing any work on or around the implement.

Lubrication Points

NOTICE

For lubrication, use good general purpose grease. Avoid mixing different brands of grease.

Mid Row Ripper™ Wing Pivot Pins

Should be lubricated once every 8 to 10 hours.

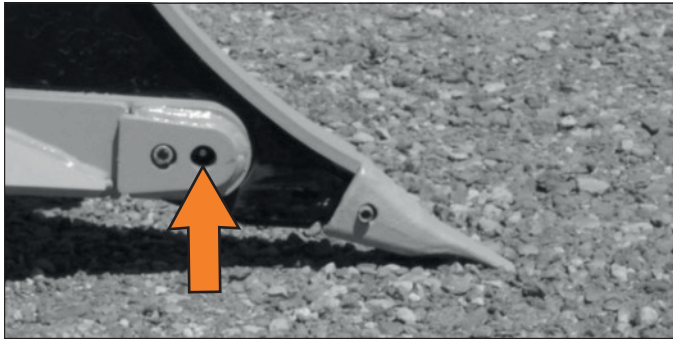

Rear Roller Bearings (Optional)

Rear roller bearings come pre-lubed from the factory. Prior to applying grease, allow 40 hours of operation time to break in the seals. Add grease to the zerk fitting on the pillow block bearings, as shown. Should be lubricated every 50 hours or weekly.

Note: Clean the fitting, then add grease until it is visibly forced out of the bearing.

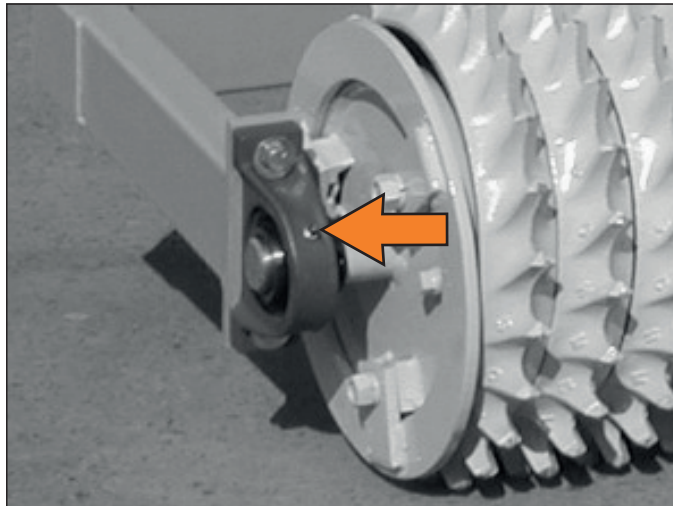

Rear Roller Frame Mounting Bushings (Optional)

Should be lubricated every 50 hours or weekly.

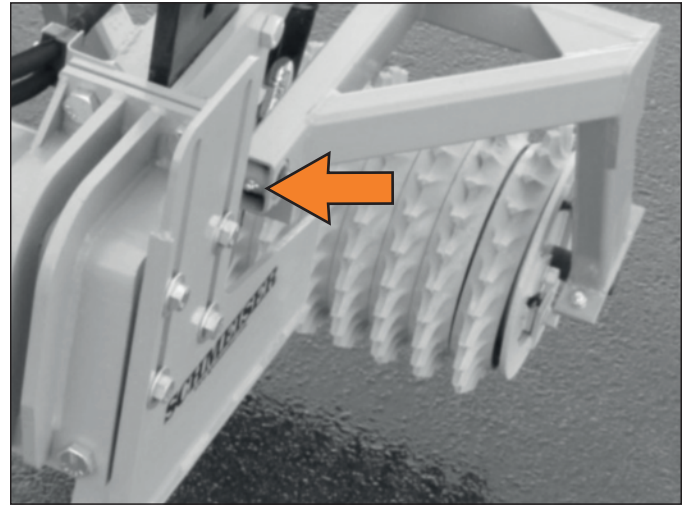

Ground Engaging Components

Ground engaging components are subject to abrasion and wear. Excessively worn components will require replacement. Replace corresponding components on both shanks at the same time for uniform performance.

Shank Point

NOTE: Unit comes with factory installed standard points (SWKS-3202). Sharp tipped points (SWKS-3209) are also available for more aggressive soil penetration.

1. Remove 7/16" x 2-1/2" roll pin, remove point.
2. Replace with new shank point and new roll pin.

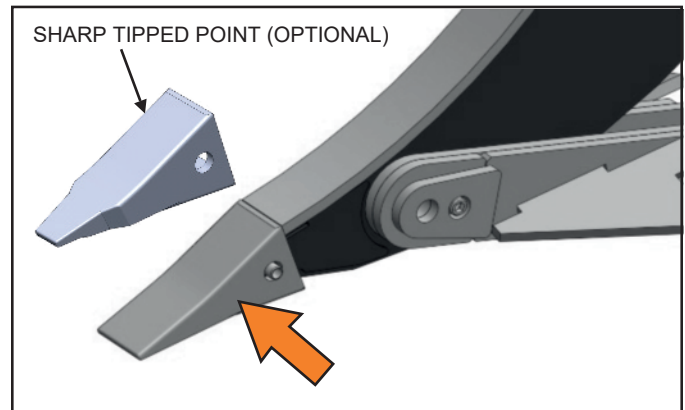

Shank Wings LH and RH

NOTE: Replace wing when it is worn flush with tip of gusset indicated below.

1. Loosen two front 3/8" x 3/4" hex socket head bolts on wing pivot pin and cap. There is no need to remove these completely when only replacing shank wings.
2. Remove two rear 3/8" x 3/4" hex socket head bolts.
3. Remove LH and RH wings.
4. Replace with new LH and RH wings (SWKS-0014, SWKS-0018).
5. Install two rear 3/8" x 3/4" hex socket head bolts.
6. Tighten front 3/8" x 3/4" hex socket head bolts.

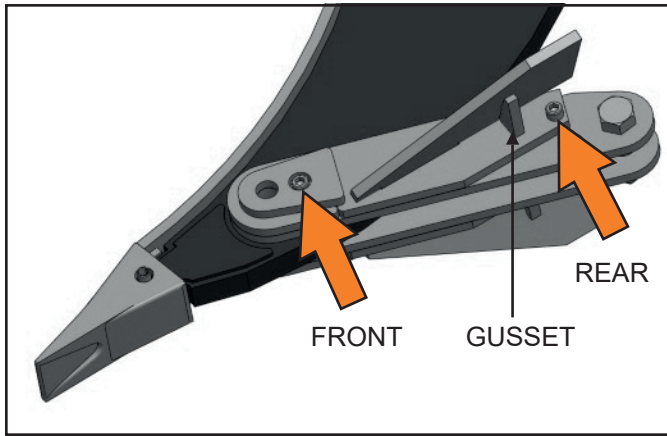

Shank Wing Pivot Pin and Cap

1. Remove two front 3/8" x 3/4" hex socket head bolts.
2. Remove one front 3/8" x 1" hex socket head bolt from wing pivot cap.
3. Remove wing pivot pin and cap.
4. Inspect internal tension bushing, replace if worn.
5. If required, tap in new internal tension bushing (GBH-24X16T) to remove old bushing.
6. Install new wing pivot pin and cap (SWKS-0046).
7. Install 3/8" x 1" and 3/8" x 3/4" hex socket head bolts.

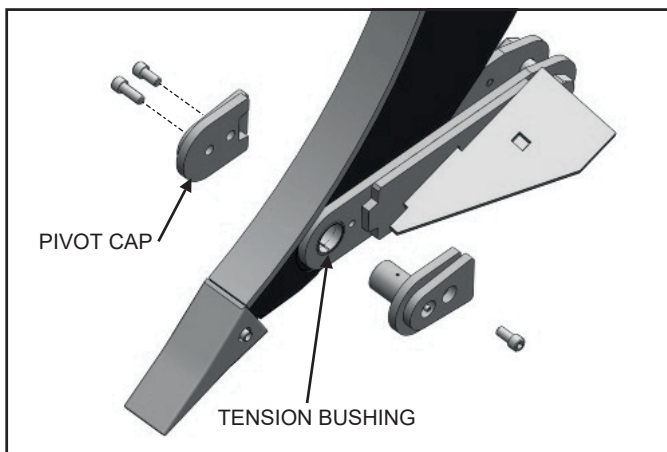

Shank Shin Guard

1. Ensure that shank point is installed.
2. Remove top 3/8" x 1-3/4" roll pin.
3. Remove old shin guard.
4. Install new shin guard (SWKS-0023) by inserting bottom into shank point.
5. Install 3/8" x 1-3/4" roll pin.

NOTE: Optional shin guard with rib (SWKS-0002) also available for harder ground conditions.

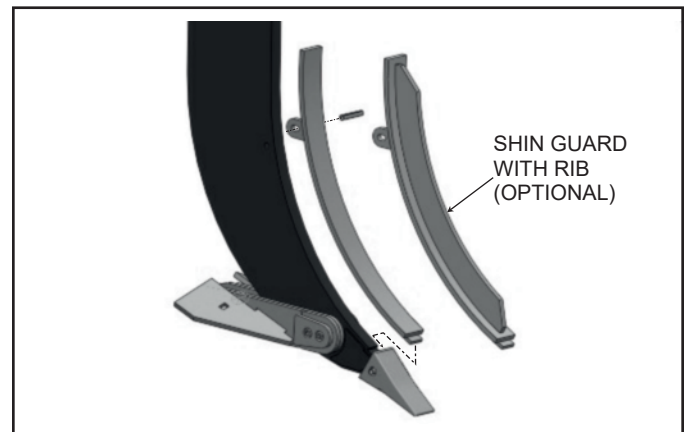



Maintenance Schedule

The period recommended is based on normal operating conditions. Severe or unusual conditions may require more frequent service.

Copy this page to continue record.

Hours and Serviced By															
Maintenance															
Before Each Use or Daily															
Ensure that all fasteners are tight, and all pins are secured in place.															
Inspect the frame for structural fractures.															
Make sure all warning decals are in place and legible.															
Inspect all hydraulic hoses and fittings for leaks or signs of wear.															
Check all ground engaging components for wear and damage. Replace if necessary.															
Lubricate zerk fittings on wing pivot pins															
Every 50 Hours or Weekly															
Perform the Daily Maintenance schedule.															
Lubricate zerk fittings on Till An' Pak™ pillow block bearings and mounting pins with a good general purpose grease.															
Every 1000 Hours or Annually															
Perform the Daily Maintenance schedule.															
Perform the Weekly Maintenance schedule.															
Remove debris and clean the entire implement with compressed air or a pressure washer.															
Remove rust and apply a coat of paint to frame surfaces where the paint has been worn off or damaged.															

STORAGE



WARNING



Understand Safety Procedures!

Read and understand all safety procedures described in this manual before performing any work on or around the implement.

Storage Preparation

After work is completed for a season, perform the following maintenance procedures before storing the implement.

1. Apply a thin layer of grease or rust preventative to all exposed metal surfaces of the adjustable mechanisms (threaded rods, etc.).
2. Check all bolted connections. Ensure that the fasteners are tight, and all retaining pins are secured in place with appropriate retaining clips.
3. Inspect the frame for structural fractures.
4. Check the ripper shanks and wear parts for wear and damage. If excessively worn or damaged, they must be replaced.
5. Make sure all the warning decals are in place and legible. Replace any worn decals as needed.
6. Thoroughly wash the Mid-Row Ripper™ with a pressure washer or water hose to remove all dirt, mud, or debris.
7. For models equipped with a rear roller, lubricate the grease fittings on the roller pillow block bearings and pivot pin bushings with a good general purpose lithium grease. Refer to “Lubrication Points” on page 21 for the location of the fittings.
8. To help prevent corrosion, remove rust and apply a coat of paint to frame surfaces where paint has been worn off or damaged.
9. Make sure the implement is stored in an area with a firm and level base to prevent it from tipping or sinking into the ground. Safety stand must be extended / lowered and secured in place for storage. For best results, always store the Mid-Row Ripper™ in a dry, protected location. Leaving this implement unprotected will shorten the service life.

Placing In Storage

1. Select an area that is dry, level, and free of debris (inside a building is ideal). Move the Mid-Row Ripper™ to its storage area.
2. Lower the Mid-Row Ripper™ onto the ground.
3. Disconnect the Mid-Row Ripper™ from the 3-point hitch and drive the tractor away from the Mid-Row Ripper™. Refer to “Detaching From Tractor” on page 21. Do not leave the tractor attached to the Mid-Row Ripper™.

Removing From Storage

Prior to use each season, perform the following inspection and maintenance.

1. Read the operator’s manual to review all safety, operational, and maintenance procedures.
2. Perform any recommended maintenance that was not completed when the implement was put into storage.
3. Visually inspect the implement for wear or damage.
4. Make sure all the warning decals are in place and legible. Replace any damaged or missing decals.
5. Attach the Mid-Row Ripper™ to the tractor 3-point hitch. Refer to “Attaching to Tractor” on page 17.

COMPONENT NOMENCLATURE

Component Locations

HD Mid-Row Ripper™

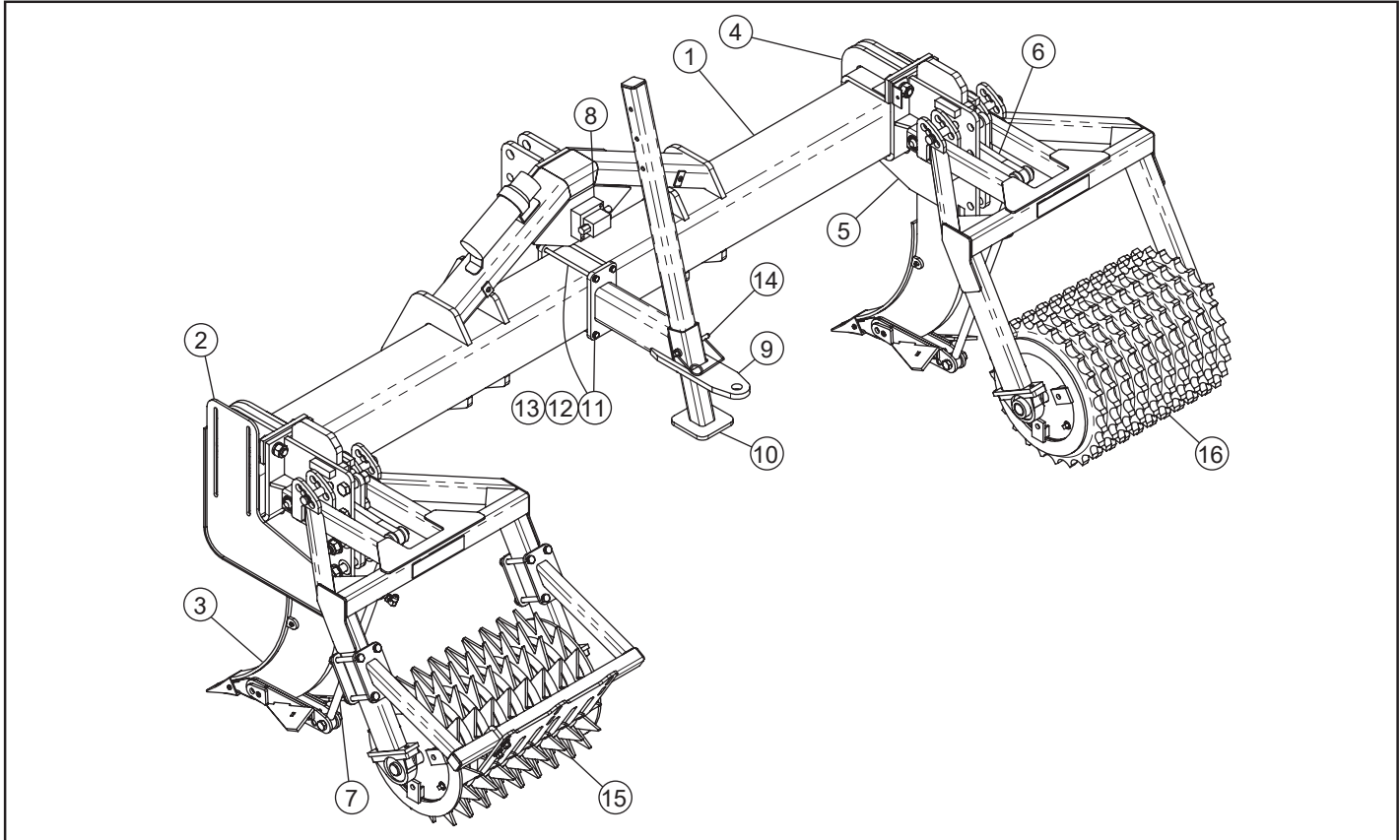

Item	Part Number	Description	Qty.
1	SWKS-MF(000)	Ripper Main Frame (specify size in inches)	1
2	SWKS-0005	Side Dirt Guard	2
3	-----	Shank Assembly (see page 30 for details)	2
4	SWKS-0006	Front Half Clamp	2
5	SWKS-0007	Shank Pocket	2
6	SWKS-0008	Cylinder Anchor for HD Mid-Row Ripper™	2
7	SWKS211-231	Hydraulic Cylinder	2
8	SWKS300-000	Hydraulic Oscillating Valve Assembly	1
9	SWKS-0036	Trail Hitch for HD Mid-Row Ripper™	1
10	SWKS-0034	Safety Stand for HD Mid-Row Ripper™	1
11	CSNC508160	1/2" X 10" Gr. 5 NC Cap Screw	4
12	HXNUT-08NC	1/2" NC Hex Nut	4
13	LWASHER-08	1/2" Lock Washer	4
14	GPN-0872HL	Pin, 1/2" X 4-1/2" Handle Lock	2
15	-----	Down Pressure Roller (see p.35 for details)	2
16	-----	Till An' Pak Roller (see p.34 for details)	2

Mini Mid-Row Ripper™

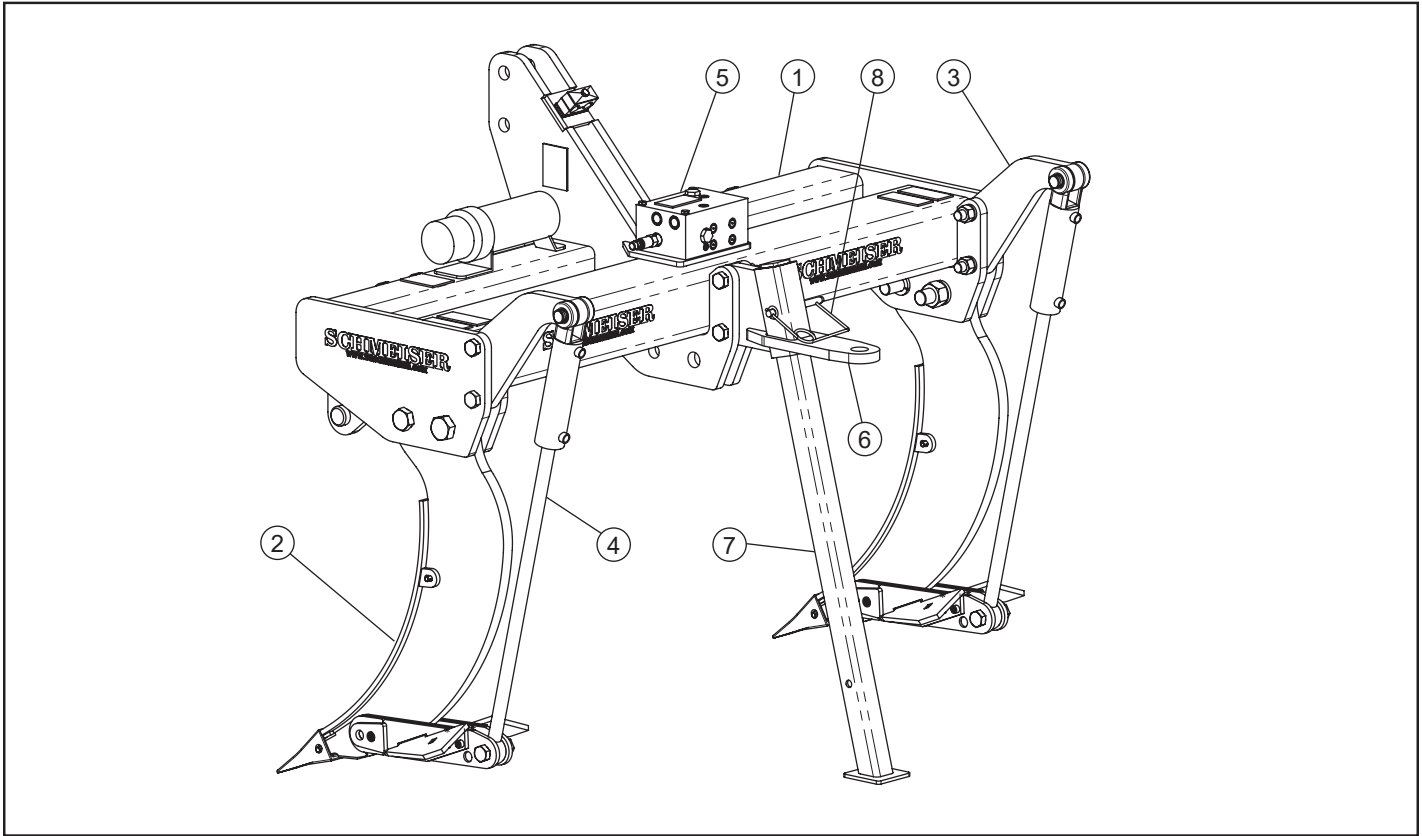

Item	Part Number	Description	Qty.
1	SWKS-MF(000)	Ripper Main Frame (specify size in inches)	1
2	-----	Shank Assembly (see page 31 for details)	2
3	SWKS-0012	Cylinder Anchor for Mini Mid-Row Ripper™	2
4	SWKS211-231	Hydraulic Cylinder	2
5	SWKS302-679	Hydraulic Reciprocating Valve Assembly	1
6	SWKS-0032	Trail Hitch for Mini Mid-Row Ripper™	1
7	SWKS-0033	Safety Stand for Mini Mid-Row Ripper™	1
8	GPN-0872HL	Pin, 1/2" X 4-1/2" Handle Lock	1

PARTS SECTION

Ordering Parts

We manufacture a quality product that requires very little maintenance or repair. However, should a part break or become damaged, our knowledgeable staff can make sure you receive the part(s) to put your unit back into operation.

HD Mid-Row Ripper™ Assembly

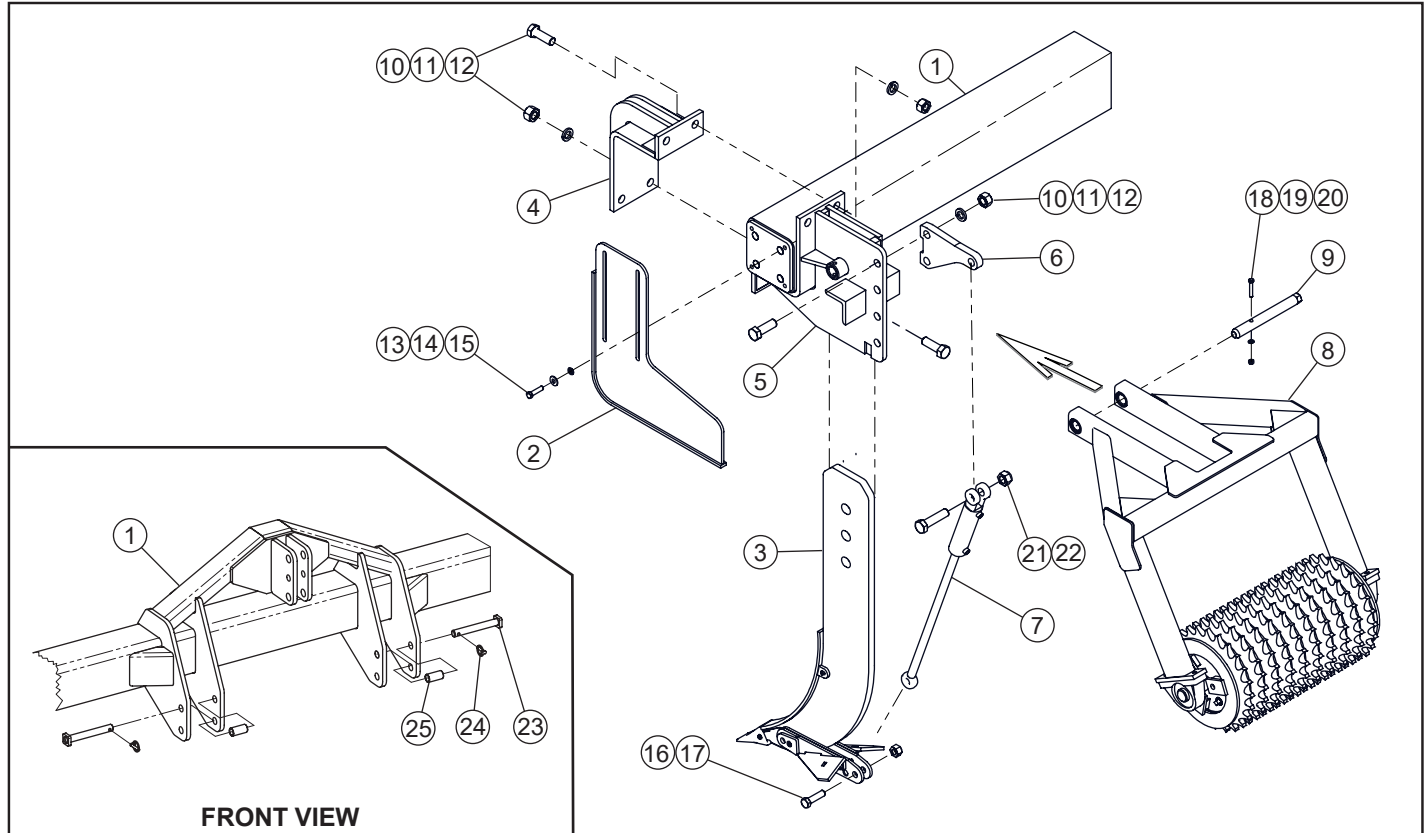

Item	Part Number	Description	Qty.
1	SWKS-MF(000)	Ripper Main Frame (specify size in inches)	1
2	SWKS-0005	Side Dirt Guard	2
3	-----	Shank Assembly (see page 32 for details)	2
4	SWKS-0006	Front Half Clamp	2
5	SWKS-0007	Shank Pocket	2
6	SWKS-0008	Cylinder Anchor for HD Mid-Row Ripper™	2
7	SWKS211-231	Hydraulic Cylinder	2
8	-----	Rear Roller (see pages 34-35 for details)	2
9	SWKS-0015	Shank Mount Pin	2
	SWKS-0015A	Shank and TP Mount Pin	2
10	CSNC516048	1" X 3" Gr. 5 NC Cap Screw	12
11	HXNUT-16NC	1" NC Hex Nut	12
12	LWASHER-16	1" Lock Washer	12

Item	Part Number	Description	Qty.
13	CSNC508032	1/2" X 2" Gr. 5 NC Cap Screw	8
14	FWASHER-08	1/2" Flat Washer	8
15	LWASHER-08	1/2" Lock Washer	8
16	CSNC512044	3/4" X 2-3/4" Gr. 5 NC Cap Screw	2
17	NYNUT-12NC	3/4" NC Nylon Lock Hex Nut	2
18	CSNC506048	3/8" X 3" Gr. 5 NC Cap Screw	2
19	HXNUT-06NC	3/8" NC Hex Nut	2
20	LWASHER-06	3/8" Lock Washer	2
21	CSNC516064	1" X 4" Gr. 5 NC Cap Screw	2
22	NYNUT-16NC	1" NC Nylon Lock Hex Nut	2
23	3VB-E	Front Pull Pin 1-1/8" Dia.	2
24	GPN-070LYN	7/16" Lynch Pin	2
25	GBH-C23L01	CA 2-3 Lift Arm Bushing	4

Mini Mid-Row Ripper™ Assembly

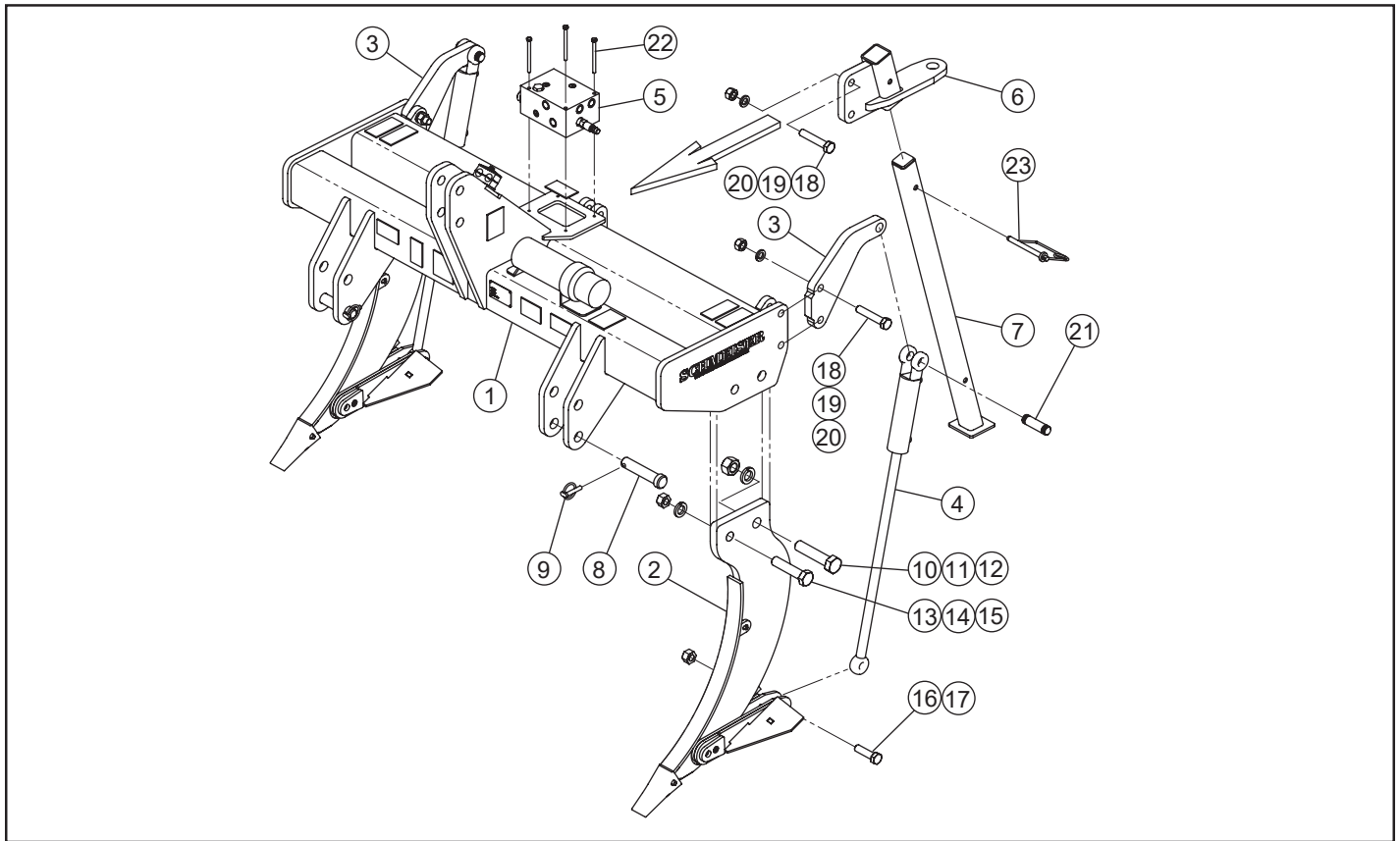

Item	Part Number	Description	Qty.
1	SWKS-MF(000)	Ripper Main Frame (specify size in inches)	1
2	-----	Shank Assembly (see page 33 for details)	2
3	SWKS-0012	Cylinder Anchor for Mini Mid-Row Ripper™	2
4	SWKS211-231	Hydraulic Cylinder	2
5	SWKS302-679	Hydraulic Reciprocating Valve Assembly	1
6	SWKS-0032	Trail Hitch for HD Mid-Row Ripper™	1
7	SWKS-0033	Safety Stand for HD Mid-Row Ripper™	1
8	GPN-24CA02S	Pin, CA 2 Short	2
9	GPN-070LYN	Pin, 7/16" Lynch	2
10	CSNC818080	1-1/8" X 5" Gr. 8 NC Cap Screw	2
11	HXNUT-18NC	1-1/8" NC Hex Nut	2
12	LWASHER-18	1-1/8" Lock Washer	2

Item	Part Number	Description	Qty.
13	RSB-03	1" X 4-1/2" Shear Bolt	2
14	HXNUT-16NC	1" NC Hex Nut	2
15	LWASHER-16	1" Lock Washer	2
16	CSNC512044	3/4" X 2-3/4" Gr. 5 NC Cap Screw	2
17	NYNUT-12NC	3/4" NC Nylon Lock Hex Nut	2
18	CSNC512064	3/4" X 4" Gr. 5 NC Cap Screw	6
19	HXNUT-12NC	3/4" NC Hex Nut	6
20	LWASHER-12	3/4" Lock Washer	6
21	GPN-1656HC	Cylinder Pin	2
22	CSNC505064	5/16" X 4" Gr. 5 NC Cap Screw	3
23	GPN-0872HL	Pin, 1/2" X 4-1/2" Handle Lock	1

Shank Assembly for HD Mid-Row

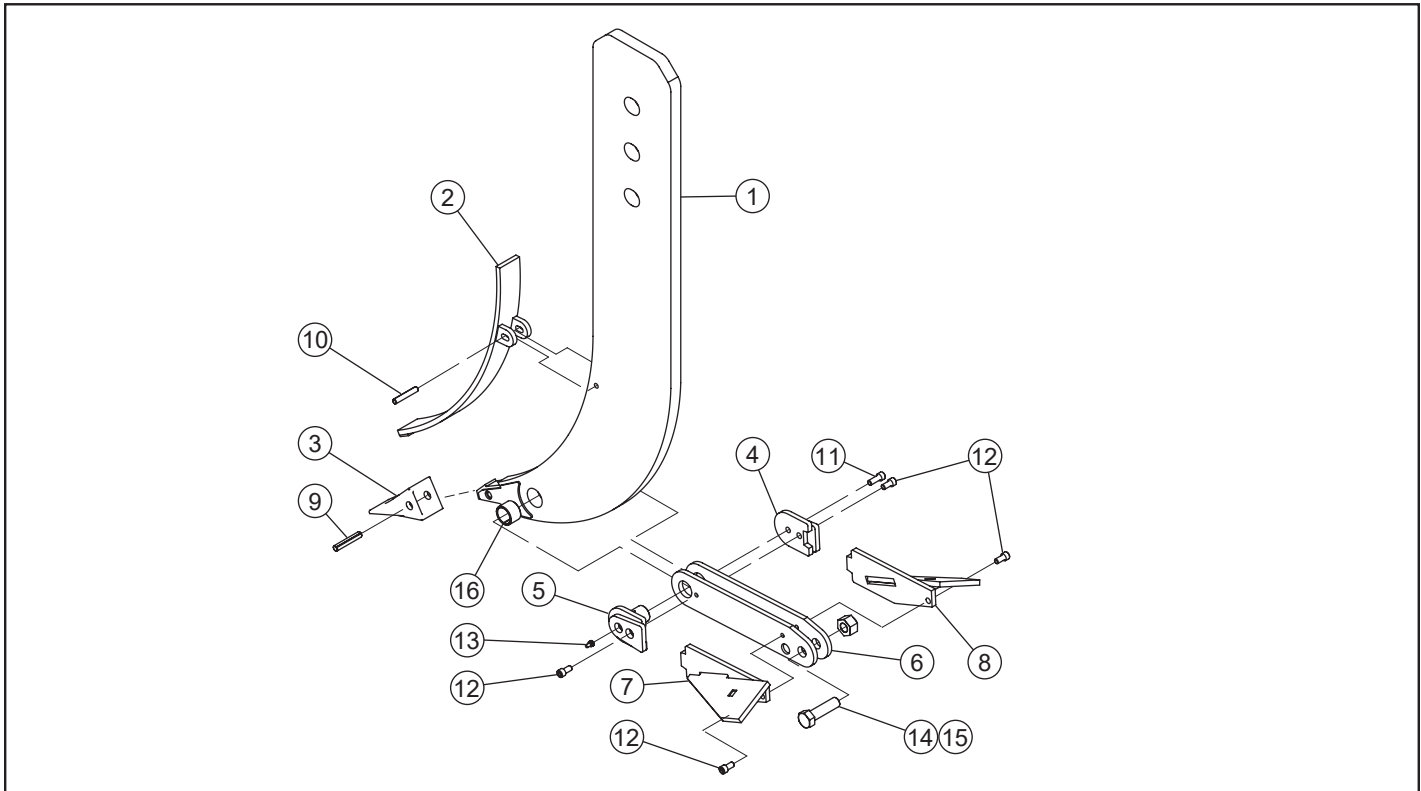

Item	Part Number	Description	Qty.
1	SWKS-0001	Shank 48" Adjustable	2
2	SWKS-0023	Shinguard without Rib (shown)	2
	SWKS-0002	Shinguard with Rib (Optional)	2
3	SWKS-3202	Shank Point Standard	2
	SWKS-3209	Shank Point Penetration (Optional)	2
4	SWKS-0045A	Wing Pivot Cap	2
5	SWKS-0045B	Wing Pivot Pin	2
6	SWKS-0004	Wing Pivot Arm	2
7	SWKS-0014	Shank Wing 8" LH	2
8	SWKS-0018	Shank Wing 8" RH	2
9	GPN-07X40R	7/16" X 2-1/2" Roll Pin	2
10	GPN-06X28R	3/8" X 1-3/4" Roll Pin	2
11	CSNC06016HS	3/8" X 1" NC Hex Socket Head Bolt	2
12	CSNC06012HS	3/8" X 3/4" NC Hex Socket Head Bolt	8
13	GMB-ZERKTH	Threaded Grease Zerk 1/8" NPT	2
14	CSNC512044	3/4" X 2-3/4" Gr. 5 NC Cap Screw	2
15	NYNUT-12NC	3/4" NC Nylon Lock Hex Nut	2
16	GBH-24X16T	Tension Bushing	2
	SWKS-0044	Wing Hardware Kit - per one shank (Includes items 9 through 12, 14, 15)	
	SWKS-0046	Pivot Pin and Cap Kit - per one shank (Includes items 4, 5, 13)	

Shank Assembly for Mini Mid-Row

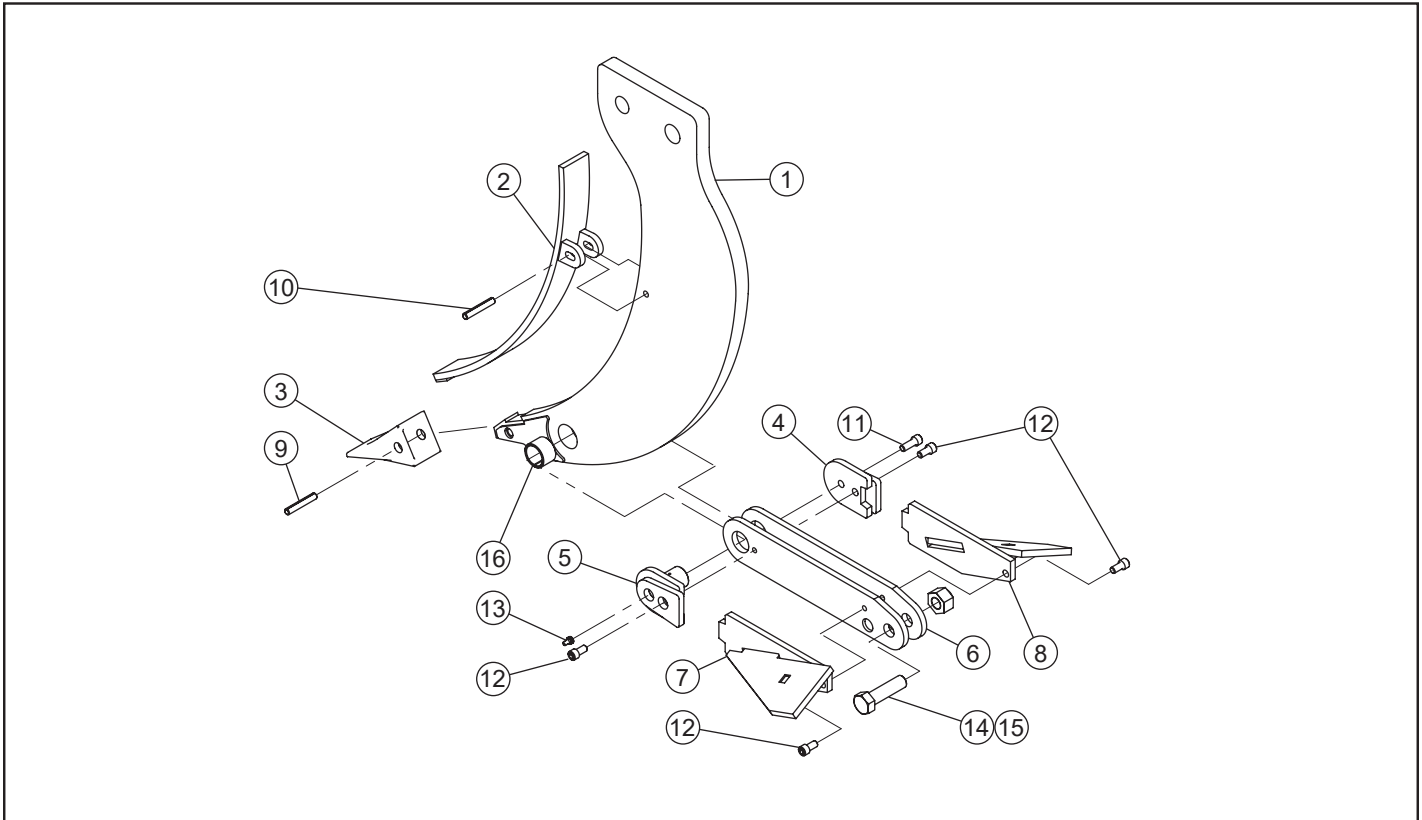

Item	Part Number	Description	Qty.
1	SWKS-0011	Shank 30" Parabolic	2
	SWKS-0023	Shinguard without Rib (shown)	2
	SWKS-0002	Shinguard with Rib (Optional)	2
3	SWKS-3202	Shank Point Standard	2
	SWKS-3209	Shank Point Penetration (Optional)	2
4	SWKS-0045A	Wing Pivot Cap	2
5	SWKS-0045B	Wing Pivot Pin	2
6	SWKS-0004	Wing Pivot Arm	2
7	SWKS-0014	Shank Wing 8" LH	2
8	SWKS-0018	Shank Wing 8" RH	2
9	GPN-07X40R	7/16" X 2-1/2" Roll Pin	2
10	GPN-06X28R	3/8" X 1-3/4" Roll Pin	2
11	CSNC06016HS	3/8" X 1" NC Hex Socket Head Bolt	2
12	CSNC06012HS	3/8" X 3/4" NC Hex Socket Head Bolt	8
13	GMB-ZERKTH	Threaded Grease Zerk 1/8" NPT	2
14	CSNC512044	3/4" X 2-3/4" Gr. 5 NC Cap Screw	2
15	NYNUT-12NC	3/4" NC Nylon Lock Hex Nut	2
16	GBH-24X16T	Tension Bushing	2
	SWKS-0044	Wing Hardware Kit - per one shank (Includes items 9 through 12, 14, 15)	
	SWKS-0046	Pivot Pin and Cap Kit - per one shank (Includes items 4, 5, 13)	

Mid-Row Ripper™ Rear Till An' Pak™ Roller Assembly (HD models) - Optional

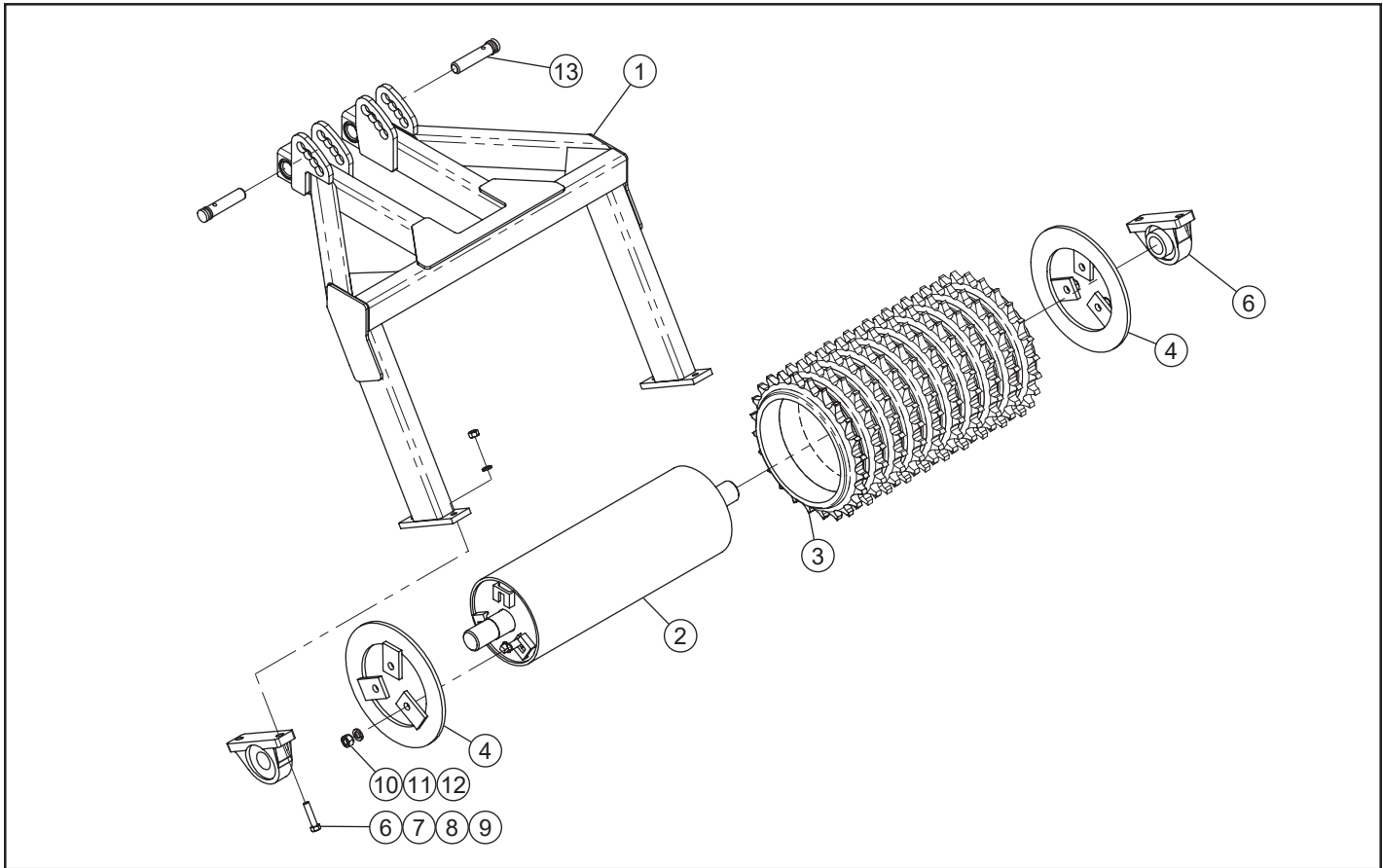

Roller Tube, Ring, and Retainer Chart

Item	Part Number	Description	Qty. per ass'y
1	SWKS-0009	2 Ft. Rear Roller Frame	1
	SWKS-0010	2.5 Ft. Rear Roller Frame	1
2	—————	Roller Tube (see table)	1
3	—————	Till An' Pak™ Ring (see table)	varies
4	—————	Roller Retainer (see table)	2
5	TPP3150	1-11/16" Pillow Block Bearings	2
6	CSNC508036	1/2" X 2-1/4" Gr.5 NC Cap Screw	4
7	HXNUT-08NC	1/2" NC Hex Nut	4
8	LWASHER-08	1/2" Lock Washer	4
9	FWASHER-08	1/2" Flat Washer	4
10	CBNC510020	5/8" X 1-1/4" NC Carriage Bolt	6
11	HXNUT-10NC	5/8" NC Hex Nut	6
12	LWASHER-10	5/8" Lock Washer	6
13	SWKS-0080	Gauging Pin	2

Tube Size	Tube Part #	Ring Size (ID / OD)	Ring Part #	Retainer Size (ID - OD)	Retainer Part #
10" x 2 Ft.	TUBE1002	12 / 16	TPP3351	10 - 14	TPP3206
10" x 2.5 Ft.	TUBE1002-6	12 / 16	TPP3351	10 - 14	TPP3206
12" x 2 Ft.	TUBE1202	14 / 20	TPP3353	12 - 18	TPP3210
12" x 2.5 Ft.	TUBE1202-6	14 / 20	TPP3353	12 - 18	TPP3210

Mid-Row Ripper™ Rear Down Pressure Roller Assembly (HD models) - Optional

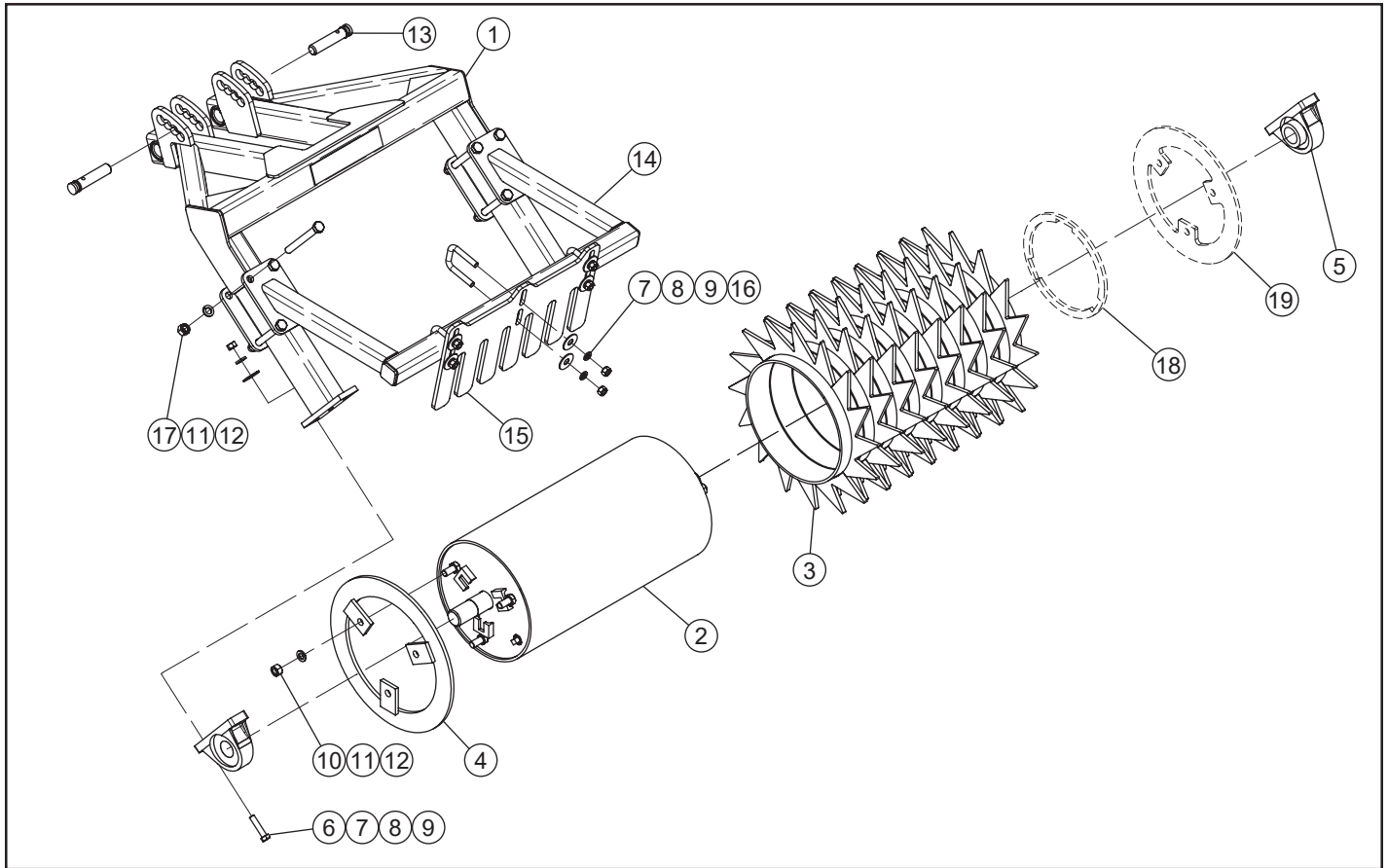

Item	Part Number	Description	Qty. Per ass'y
1	SWKS-0009	2 Ft. Rear Roller Frame	1
	SWKS-0010	2.5 Ft. Rear Roller Frame	1
2	TUBE 1002	2 Ft. Roller Tube	1
	TUBE 1002-6	2.5 Ft Roller Tube	1
3	DPR-12X20S	Star Steel Ring For 2 Ft Unit	8
	DPR-12X20S	Star Steel Ring For 2.5 Ft Unit	11
4*	TPP3206	Retainer (2 Ft. Unit Only)	2
5	TPP3150	1-11/16" Pillow Block Bearings	2
6	CSNC508036	1/2" X 2-1/4" Gr. 5 NC Cap Screw	4
7	HXNUT-08NC	1/2" NC Hex Nut	10 - 12
8	LWASHER-08	1/2" Lock Washer	10 - 12
9	FWASHER-08	1/2" Flat Washer	10 - 12

Item	Part Number	Description	Qty. per ass'y
10	CBNC510020	5/8" X 1-1/4" NC Carriage Bolt	6
11	HXNUT-10NC	5/8" NC Hex Nut	14
12	LWASHER-10	5/8" Lock Washer	14
13	SWKS-0080	Gauging Pin	2
14	SWKS-0070	DPR Roller Scraper Frame 2'	1
	SWKS-0071	DPR Roller Scraper Frame 2.5'	1
15	SWKS-0075	DPR Roller Scraper 2 Ft.	1
	SWKS-0076	DPR Roller Scraper 2.5 Ft.	1
16	UBNC08X33S	1/2" Square U-Bolt	3 - 4
17	CSNC510088	5/8" X 5-1/2" NC Gr.5 Cap Screw	8
18*	DPR-00E007	Roller Shim Plate (2.5 Ft. Only)	2
19*	DPR-00E008	Flat Retainer (2.5 Ft. Only)	2

Mid-Row Ripper™ HD Frame Extension Assembly

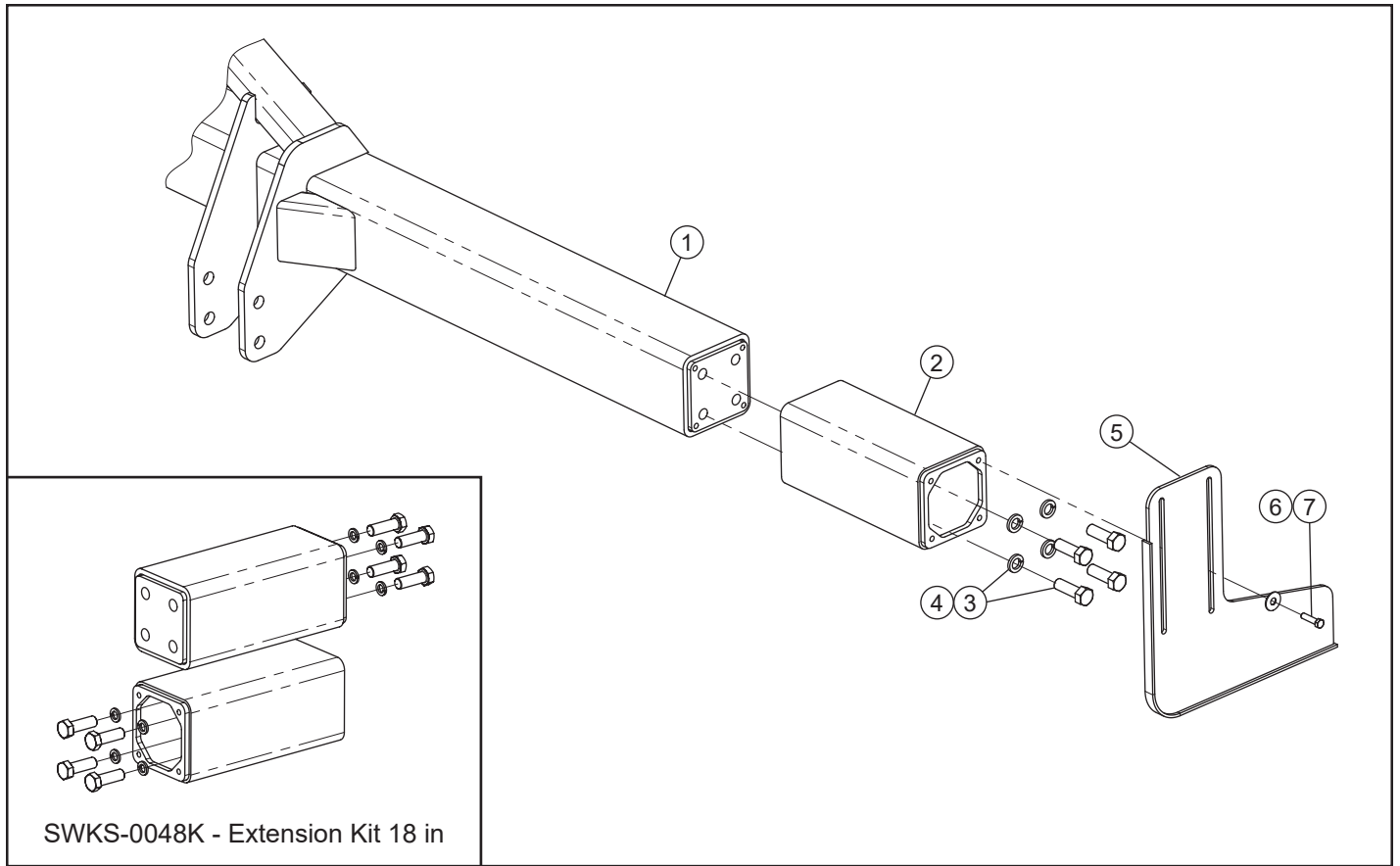

Item	Part Number	Description	Qty.
1	SWKS-MF(000)	Mid-Row Ripper™ Frame (specify size in inches)	1
2	SWKS-0048	Frame Extension 18 in	2
3	CSNC816040	1" X 2-1/2" Gr. 8 NC Cap Screw	8
4	LWASHER-16	1" Lock Washer	8
5	SWKS-0005	Side Guard	2
6	CSNC508024	1/2" X 1-1/2" Gr. 5 NC Cap Screw	8
7	FWASHER-08	1/2" Flat Washer	8

Mid-Row Ripper™ HD Dirt Crowder Assembly - Pair (Optional)

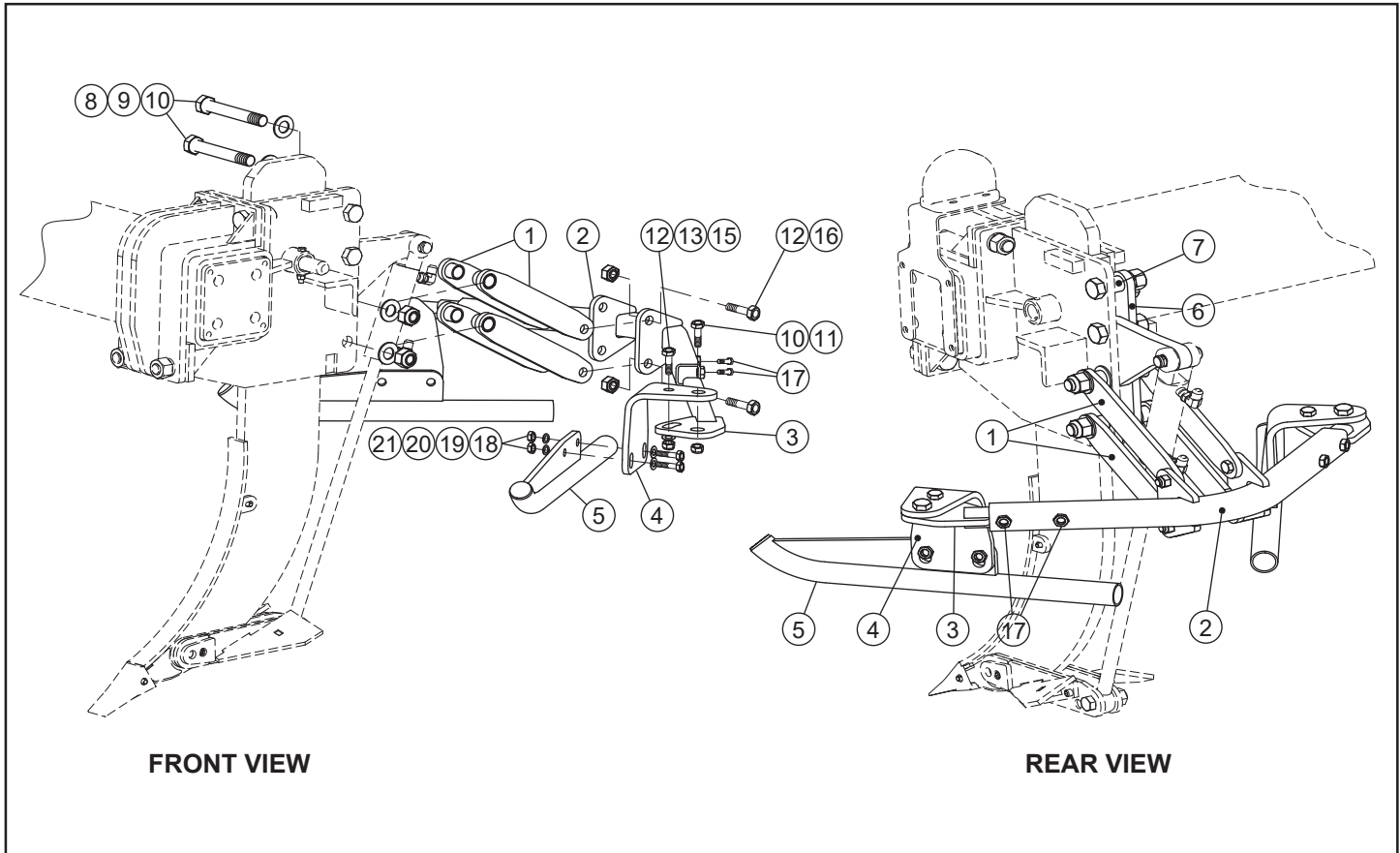

Item	Part Number	Description	Qty. per Ass'y (Pair)
1	SWKS-0051	Parallel Link	8
2	SWKS-0052	Crowder Frame	2
3	SWKS-0053	Extension Arm	4
4	SWKS-054	Mounting Bracket	4
5	SWKS-055	Pipe Ski	4
6	SWKS-057	Mounting Bar	2
7	SWKS-058	Pipe Spacer	4
8	CSNC516112	1" X 7" NC Cap Screw	4
9	FWASHER-16	1" Flat Washer	16
10	NYNUT-16NC	1" NC Nylon Lock Nut ZP	8
11	CSNC516040	1" X 2-1/2" NC Cap Screw	4
12	CSNC512040	3/4" X 2-1/2" NC Cap Screw	12
13	LWASHER-12	3/4" Lock Washer ZP	4
14	FWASHER-12	3/4" Flat Washer ZP	16
15	HXNUT-12NC	3/4" NC Hex Nut ZP	4
16	NYNUT-12NC	3/4" NC Nylon Lock Nut	8
17	CSNC510020	5/8" X 1-1/4" NC Cap Screw	8
18	CSNC510028	5/8" X 1-3/4" NC Cap Screw	8
19	FWASHER-10	5/8" Flat Washer ZP	8
20	LWASHER-10	5/8" Lock Washer ZP	8
21	HXNUT-10NC	5/8" NC Hex Nut ZP	8

Hydraulic Diagram for Mid-Row Ripper™ (HD and Mini)

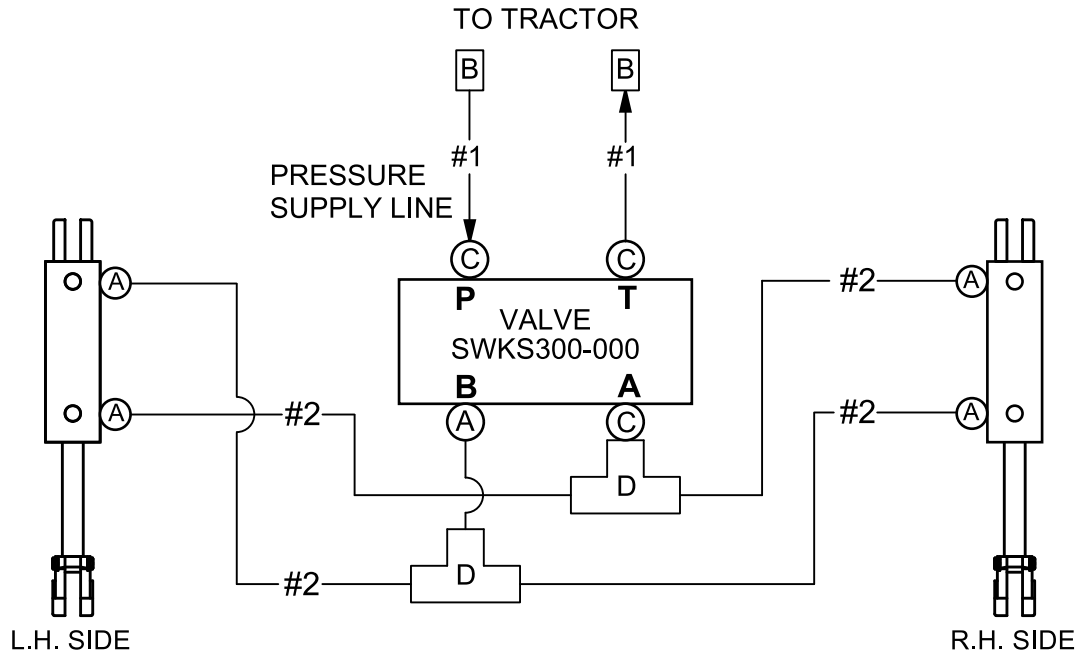

Fittings for Mid-Row Rippers™

ALL HOSE KITS INCLUDE HOSES AND FITTINGS.

FITTING	PART #	DESCRIPTION	Q'TY
A	FMBMJ9088	1/2" MB-MJ 90° Elbow	5
B	FFB08TIP	Hose Pioneer Tip	2
C	FMBMJ88C	1/2" MB-MJ Straight	3
D	FMJMJFJXT08	1/2" MJ-MJ-FJX Tee	2

Valve and Hydraulic Cylinders

##	PART #	DESCRIPTION	Q'TY
1	SWKS300-000	Oscillating Valve Assembly	1
2	SWKS211-231	2" x 2-1/2" Hyd. Cylinder	2

Hoses for HD Mid-Row Ripper™

HOSE UNIT	# 1 (2) ea.	# 2 (4) ea.	HOSE KIT #
5 Ft.	56"	45"	SWKS315-148
6 Ft.	56"	63"	SWKS315-136
7 Ft.	56"	69"	SWKS315-137
8 Ft.	56"	75"	SWKS315-138
10 Ft.	56"	87"	SWKS315-120
11 Ft.	56"	93"	SWKS315-131
12 Ft.	56"	99"	SWKS315-132
15 Ft.	56"	117"	SWKS315-133

Hoses for Mini Mid-Row Ripper™

HOSE UNIT	#1 (2) ea	#2 (4) ea	HOSE KIT #
3 Ft.	56"	35"	SWKS315-135
4 Ft.	56"	40"	SWKS315-147
5 Ft.	56"	45"	SWKS315-148

NOTE: ALL HOSES ARE 6KT-8JFX-8MB

NOTE: ALL # 1 HOSES ARE 6M3K-MTF 8MP-8FJX
ALL # 2 HOSES ARE 6M3K-MTF 8FJX-8FJX



LIMITED WARRANTY STATEMENT

T.G. Schmeiser Co., Inc.

P.O. Box 1392 – Selma, CA 93662

Phone (559) 268-8128 Fax (559) 268-3279

T. G. Schmeiser Co., Inc. warrants each new Schmeiser® product to be free from defects in material and workmanship. This warranty is applicable only for the normal service life expectancy of the product or components, not to exceed twelve (12) consecutive months from the date of delivery of the new Schmeiser product to the original purchaser.

Genuine T. G. Schmeiser Co., Inc. replacement parts and components will be warranted for 90 days from date of purchase, or the remainder of the original equipment warranty period, whichever is longer.

Under no circumstances will it cover any merchandise or components thereof, which, in the opinion of the company, has been subjected to misuse, unauthorized modifications, alteration, an accident or if repairs have been made with parts other than those obtainable through T. G. Schmeiser Co., Inc.

The Company in no way warrants engines, batteries, cylinders, tires or other trade accessories since these items are warranted separately by their respective manufacturer. Expendable components such as points, shanks, blades, rings, bearings, teeth, and the like are excluded from this warranty.

Our obligation under this warranty shall be limited to repairing or replacing, free of charge to the original purchaser, any part that, in our judgment, shall show evidence of such defect, provided further that such part shall be returned within thirty (30) days from date of failure to T. G. Schmeiser Co., Inc., routed through the dealer and distributor from whom the purchase was made, transportation charges prepaid.

This warranty shall not be interpreted to render T. G. Schmeiser Co., Inc. liable for injury or damages of any kind or nature to person or property. This warranty does not extend to the loss of crops, loss because of delay in harvesting, or any expense or loss incurred for labor, substitute machinery, rental or for any other reason.

Except as set forth above, T. G. Schmeiser Co., Inc. shall have no obligation or liability of any kind on account of any of its equipment and shall not be liable for special or consequential damages. T. G. Schmeiser Co., Inc. makes no other warranty, expressed or implied, and, specifically, T. G. Schmeiser Co., Inc. disclaims any implied warranty or merchantability or fitness for a particular purpose. Some states or provinces do not permit limitations or exclusions of implied warranties or incidental or consequential damages, so the limitations or exclusion in this warranty may not apply.

This warranty is subject to any existing conditions of supply, which may directly affect our ability to obtain materials or manufacture replacement parts.

T. G. Schmeiser Co., Inc. reserves the right to make improvements in design or changes in specifications at any time, without incurring any obligation to owners of units previously sold.

No one is authorized to alter, modify or enlarge this warranty nor the exclusion, limitations and reservations.

**WARRANTY VOID IF NOT REGISTERED
WITHIN 30 DAYS OF PURCHASE DATE**



**P.O. Box 1392
Selma, CA 93662
(559) 268-8128
WEB: www.TGSchmeiser.com**

