

# **FOLDING 4-BAR TILL AN' BEDDER (X - GENERATION)**

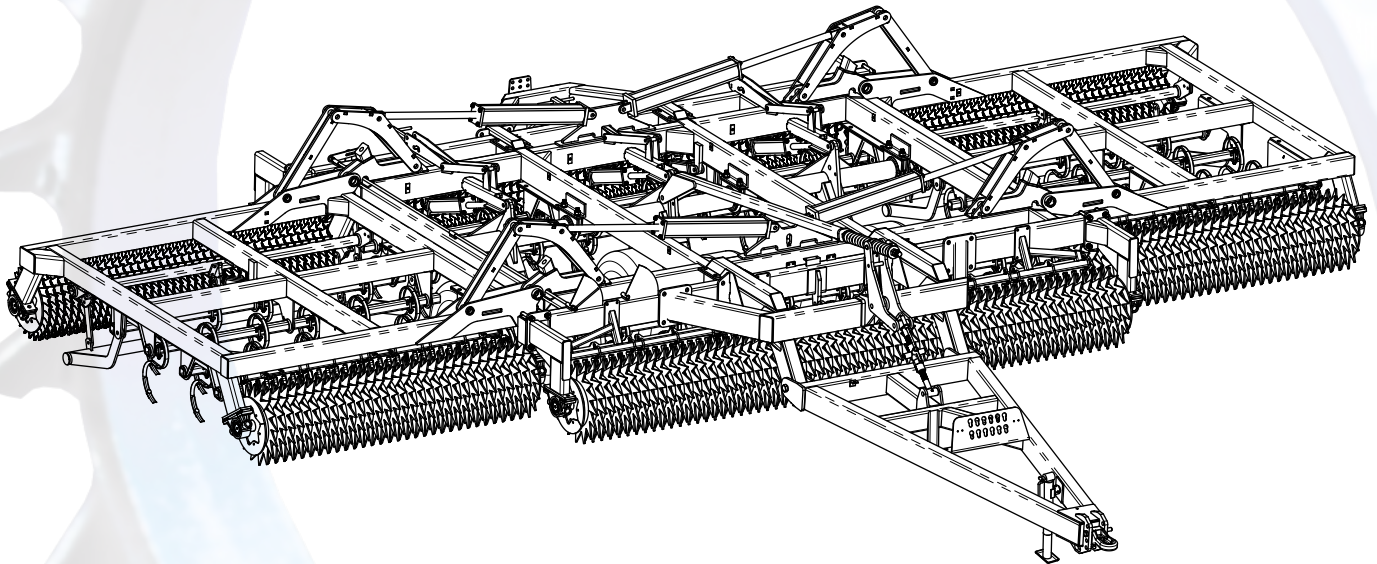

## **T. G. SCHMEISER**

# **OPERATION AND PARTS MANUAL**

**Version 2.3  
November 2021**

*Read and understand the manual. This manual provides information and procedures to safely operate and maintain the Folding 4-Bar Till An' Bedder.*







**CONTENTS**

<b>INTRODUCTION.....</b>	<b>4</b>	Operating Instructions with Secondary Unit	
Engineered for Long Life.....	4	Attached to Rear Trail Hitch.....	19
Serial Number Information.....	4	Towing Instructions.....	19
Replacement Parts.....	4	Detaching from Tractor.....	19
Warranty Information.....	4	Initial Set Up Check List.....	20
Serial Number Location.....	4	Implement Break In.....	20
Factory Contact Information.....	4		
Dealer Contact Information.....	4	<b>MAINTENANCE.....</b>	<b>20</b>
<b>SAFETY.....</b>	<b>5</b>	Lubrication Points.....	20
Safety Alert Symbols.....	5	Wheel Hub Bearings.....	20
Safety Icons Nomenclature.....	6	Turnbuckles and Linkage.....	20
Personal Protection/Important Information..	6	Ground Engaging Components.....	20
Prohibited Actions.....	6	Roller Rings.....	21
Hazard Avoidance.....	6	Steel Ring Scrapers (Optional).....	21
General Safety.....	7	S-Tines.....	21
Assembly Safety.....	7	Service Items.....	21
Towing Safety.....	8	Tires.....	21
Safety Chain.....	8	Replacing Front to Rear Level Springs..	21
Highway and Transport Operations.....	9	Hydraulic Hoses.....	21
Operation Safety.....	9	Maintenance Schedule.....	22
Tractor Requirements.....	9	<b>STORAGE.....</b>	<b>22</b>
Tractor Safety Devices.....	10	Storage Preparation.....	22
ROPS and Seat Belt.....	10	Placing in storage.....	23
Attaching to Tractor.....	10	Removing From Storage.....	23
Prior to Connecting Unit.....	10	<b>PARTS SECTION.....</b>	<b>24</b>
Connecting to the Tractor.....	10	<b>HYDRAULIC DIAGRAMS.....</b>	<b>47</b>
Hydraulic Component Safety.....	10	<b>NOTES.....</b>	<b>52</b>
Maintenance Safety.....	11	<b>LIMITED WARRANTY STATEMENT.....</b>	<b>55</b>
Tires Safety.....	12		
Bolt Torque Requirements.....	12		
Tire and Lug Torque Specifications.....	12		
Welding Repairs.....	13		
Storage Safety.....	13		
Disposal of Equipment at End of Useful Life.....	13		
<b>SAFETY MARKING AND LIGHTING.....</b>	<b>14</b>		
<b>SAFETY SIGNS AND DECALS.....</b>	<b>15</b>		
Safety Signs and Decals.....	15		
<b>ASSEMBLY AND OPERATION.....</b>	<b>17</b>		
Assembly Instructions.....	17		
Attaching to Tractor.....	18		
Adjusting 4-Bar Folding Till An' Bedder.....	18		
Prior to Adjustment.....	18		
Front to Rear Level Adjustment.....	18		
Operating Instructions.....	19		

## INTRODUCTION

Your Schmeiser Folding Till An' Bedder (implement) is designed to provide many years of dependable service. This manual has been prepared to instruct the user in the safe and efficient operation of this implement. Read and understand the manual thoroughly and follow all instructions carefully.

### Engineered for Long Life

Our products are engineered to work in conjunction with other farm implements. The Folding Till An' Bedder helps save time and money when attached behind a plow or disc, seeder, fertilizer spreader, or fumigator.

### Serial Number Information

Record the serial number, model number, and date purchased in the space provided in the Serial Number Location section. Be sure to have this information whenever contacting the dealer to order parts or attachments for this implement.

### Replacement Parts

Should this implement require replacement parts, contact your local Schmeiser dealer. Always order genuine Schmeiser OEM replacement parts.

### Warranty Information

It is important that the Warranty Card be completed and sent to Schmeiser. The warranty will not be valid until the information is on-file at Schmeiser. If information not contained in this manual is needed, contact your Schmeiser dealer.

Thank you for buying a Schmeiser Folding Till An' Bedder.

## Serial Number Location

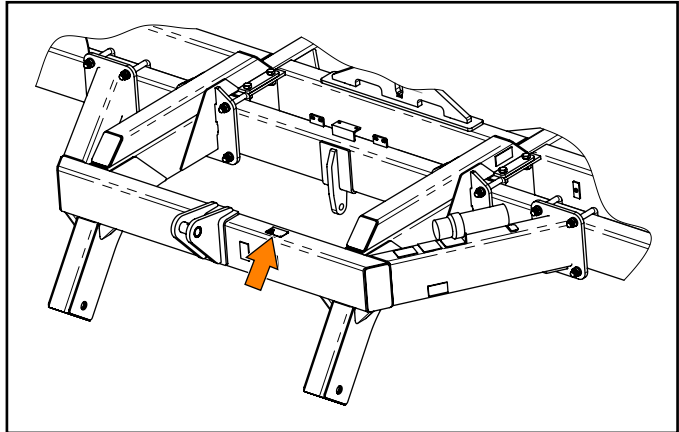

Serial No. \_\_\_\_\_

Model No. \_\_\_\_\_

Date Purchased. \_\_\_\_\_

Dealer Name. \_\_\_\_\_

### Factory Contact Information

For questions not answered in this manual, if additional copies are required, or the manual is damaged, please contact your local dealer or:

T. G. Schmeiser Co., Inc.  
P.O. Box 1392  
Selma, CA 93662

Phone: (559) 268-8128  
Fax: (559) 268-3279  
E-mail: sales@tgschmeiser.com  
Web: www.tgschmeiser.com

Additional copies of this manual can also be downloaded at [www.tgschmeiser.com](http://www.tgschmeiser.com).

### Dealer Contact Information

For replacement decals, questions, or to order parts, contact your dealer:

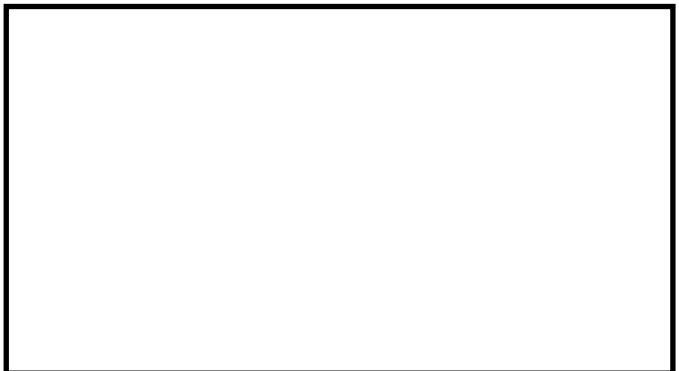



## SAFETY

Carefully read and follow all safety precautions before operation. There are obvious and hidden potential hazards involved in the operation of this implement. Serious injury or death may occur unless care is taken to ensure the safety of both the operator and any other persons in the area. Avoid potential danger by taking extra time for thought and a more careful approach to the use of this implement.

Most work related accidents are caused by failure to observe basic safety rules or precautions. An accident can often be avoided by recognizing potentially hazardous situations before an accident occurs. As you assemble, operate, or maintain the unit, you must be alert to potential hazards. You should also have the necessary training, skills, and tools to perform any assembly or maintenance procedures.

Improper operation and maintenance of this unit could result in a dangerous situation that could cause injury or death. T.G. Schmeiser cannot anticipate every possible circumstance that might involve a potential hazard. The warnings in this manual and on the product are, therefore, not all-inclusive. If a method of operation not specifically recommended by us is used, you must satisfy yourself that it is safe for you and for others. You should also ensure that the unit will not be damaged or be made unsafe by the methods that you choose.

The information, specifications, and illustrations in this manual are based on the information that was available at the time this material was written and are subject to change without notice.

## Safety Alert Symbols



This is the safety alert symbol. It is used to alert you to potential personal injury hazards. Obey all safety messages that follow this symbol to avoid possible injury or death.

This manual contains DANGERS, SAFETY INSTRUCTIONS, CAUTIONS, IMPORTANT NOTICES, and NOTES which must be followed to prevent the possibility of improper service, damage to the equipment, personal injury, or death. The following key words call the readers attention to potential hazards.

Hazards are identified by the "Safety Alert Symbol" and followed by a signal word such as "DANGER", "WARNING", or "CAUTION".

### **DANGER**

**Indicates an imminently hazardous situation which, if not avoided, will result in death or serious injury. This signal word is limited to the most extreme situations.**

### **WARNING**

**Indicates a potentially hazardous situation which, if not avoided, could result in death or serious injury.**

### **CAUTION**

**Indicates a potentially hazardous situation which, if not avoided, may result in minor or moderate injury.**

### **NOTICE**

**Indicates that equipment or property damage can result if instructions are not followed.**

### **SAFETY INSTRUCTIONS**

**Safety instructions (or equivalent) signs indicate specific safety-related instructions or procedures.**

**Note:** Contains additional information important to a procedure.

## Safety Icons Nomenclature

This manual and the equipment has numerous safety icons.

These safety icons provide important operating instructions which alert you to potential personal injury hazards.

## Personal Protection/Important Information

 READ THE MANUAL

 THINK SAFETY

 MAINTENANCE PROCEDURE

 WEIGHT RATING

 EYE PROTECTION

 HAND PROTECTION

 HEAD PROTECTION

 HEARING PROTECTION

 INSPECT EQUIPMENT

 OEM PARTS ONLY

 PLACE IN NEUTRAL

 PROTECTIVE SHOES

 REMOVE KEY

 DAMAGED HAZARD LABEL

 SLOW VEHICLE PLACARD

 SET PARKING BRAKE

 STOP ENGINE

 SUPPORT STAND USAGE

 USE PROPER TOOLS

 VISUALLY INSPECT

 USE ROPS

 USE CORRECT PARTS

## Prohibited Actions

 DO NOT ALTER OR MODIFY

 DO NOT LEAVE OUT TOOLS

 DO NOT WELD

 NO ALCOHOL

 NO CHILDREN

 NO DRUGS

 NO PASSENGERS

 NO RIDERS

 NO BYSTANDERS

## Hazard Avoidance

 BLOCK WHEELS

 CRUSHING HAZARD (body)

 CRUSHING HAZARD (foot)

 CRUSH HAZARD (rolling over)

 DEFECTIVE OR BROKEN PART

 FALLING HAZARD

 MAINTAIN SAFE DISTANCE

 OVERTURN HAZARD

 PINCH POINT HAZARD

 SAFETY ALERT SYMBOL

 SHARP OBJECT HAZARD

 ZERO PRESSURE

 COMPRESSED AIR HAZARD

 CRUSH HAZARD

 CRUSH HAZARD

 HIGH PRESSURE FLUID HAZARD

 HOT SURFACE HAZARD

 HEAVY OBJECT HAZARD

**GENERAL SAFETY**

**⚠️ WARNING**

**Read and Understand Manual**  
 To prevent personal injury or even death, be sure you read and understand all of the instructions in this manual and other related OEM equipment manuals! This equipment is dangerous to children and persons unfamiliar with its operation. The operator should be a responsible adult familiar with farm machinery and trained in this equipment's operations. Do not allow persons to operate or maintain this unit until they have read this manual and have developed a thorough understanding of the safety precautions and how it works.

This unit was designed for a specific application; DO NOT modify or use this unit for any application other than that for which it was designed.

Units operated improperly or by untrained personnel can be dangerous!

**Fall Hazard**  
 Do not use this implement as a work platform. Do not stand on top of the unit at any time. Do not ride on the tractor or the implement or allow others to ride.

**Crush Hazard (Rolling Over)**  
 To prevent serious injury or death, before disconnecting, leaving the operator's seat, servicing, adjusting, repairing, or performing other work on the implement, ALWAYS:

1. Stop the tractor or towing vehicle.
2. Shut off the engine and remove the ignition key.
3. Set the brakes.
4. Make sure wheel cylinder transport lock is attached.
5. Relieve hydraulic fluid pressure.

**Injury Hazard**  
 Do not permit children to play on or around the unit.

**Impaired Operator Hazard**  
 Do not attempt to operate this unit under the influence of drugs or alcohol. Review the safety instructions with all users annually.

**Pinch Point /Sharp Object Hazard**  
 Do not place any body parts between moving and / or stationary parts. The weight of the implement will easily cause serious bodily injury.

**⚠️** To prevent injury, use a tractor equipped with a Roll Over Protective System (ROPS).

**Visually Inspect**  
 Visually inspect the unit for any loose bolts, worn parts, or cracked welds, and make necessary repairs before using the unit.

**Personal Protection Equipment**  
 When working around or operating this unit, wear appropriate personal protective equipment. This list includes but is not limited to:

- A hard hat
- Protective shoes with slip resistant soles
- Protective goggles, glasses, or face shield
- Heavy gloves and protective clothing
- Ear muffs or plugs

**Use Properly Rated Tools**  
 To prevent serious injury: Use sufficient tools, jacks, and hoists that have the capacity for the job.

**NO PASSENGERS ALLOWED**  
 Do not carry passengers anywhere on or in the tractor or implement.

**Rolling Hazard**  
 To prevent serious injury, lock the wheels when performing assembly, maintenance, repairs, or when preparing for storage.

**ASSEMBLY SAFETY**

**⚠️ WARNING**

**Crush Hazard**  
 Use support blocks or safety stands rated to support the load when assembling the unit or performing maintenance. Never work under equipment supported by hydraulics. Hydraulics can drop equipment instantly if controls are actuated even when power to the hydraulics is shut off.

**Trapped Air Hazard**  
 When installing, replacing, or repairing hydraulic system cylinders or parts, make sure that the entire system is charged and free of air before resuming operations. Failure to bleed the system of all air can result in improper machine operation, causing severe injury.

## TOWING SAFETY



### WARNING



#### Unexpected Separation Hazard

If the safety chain does not have a current certification tag, do not use the unit until properly certified chains are installed. Substandard safety chains could allow the unit to separate from the tow vehicle, resulting in equipment damage and personal injury.



#### Loss of Control

A minimum of 20% of the combined tractor and equipment weight should be on the front wheels to ensure adequate stability during transport and operation. To avoid serious injury or death from a loss of control accident, maintain 20% weight on the front wheels. Add front end weight if necessary.



Hitch and coupling on the towing vehicle must be rated equal to, or greater than, the unit's "gross vehicle weight rating" (GVWR).

## SAFETY INSTRUCTIONS



Towing the implement requires care! Both the implement and tow vehicle must be in good working condition. Securely attach the unit to the tow vehicle using a high strength, appropriately sized hitch pin with a mechanical retainer and attach the safety chain.



Check the tires for tread wear, inflation pressure, and overall condition before towing the unit.



Inspect the hitch and coupling for wear or damage. DO NOT tow the unit using a defective hitch or coupling!



Make sure the lug nuts holding the wheels are tight (torque to specifications) and that none are missing.



Do not allow anyone to stand between the tongue or hitch and the towing vehicle when backing up to the unit.

Operate the towing vehicle from the operator's seat only.



When transporting, remember the implement may be wider than your tractor and extreme care must be taken to allow for safe clearance.



Be aware of physical surroundings and especially bystanders, particularly children, before moving the unit! This is particularly important with higher noise levels and quiet cabs, as you may not hear people shouting.

Never use independent braking with unit in tow as loss of control and/or upset of unit may result.

Always drive at a safe speed relative to local conditions, and ensure that your speed is low enough for an emergency stop to be safe and secure. Keep speed to a minimum.

Reduce speed prior to turns to avoid the risk of overturning.

Avoid sudden uphill turns on steep slopes.

Always keep the tractor or towing vehicle in gear to provide engine braking when going downhill. Do not coast.

Watch for overhead obstructions and side clearances while transporting.

Always operate equipment in a position to provide maximum visibility at all times. Make allowances for increased length and weight of the equipment when making turns, stopping, etc.

## Safety Chain

### SAFETY INSTRUCTIONS



Make sure the safety chain from the unit is securely fastened to the tow vehicle.

Always follow state and local regulations regarding a safety chain when towing farm equipment on a public highway.

Do not use any device other than an approved safety chain. Only a safety chain (not an elastic or nylon/plastic tow strap) should be used to retain the connection between the tow vehicle and the unit in the event of separation of the primary attaching system.

## Highway and Transport Operations

### SAFETY INSTRUCTIONS

 Do not exceed a towing speed of more than 20 mph (32 KPH) on a public roadway. Tires supplied by the manufacturer are designed to operate NO MORE THAN 20 mph. Do not exceed the maximum speed or tire failure may occur.

 When transporting the implement on public roads, use approved accessory lighting, flags, or other necessary warning devices to protect operators of other vehicles on the highway during daytime and nighttime transport. Various safety lights and devices are available from your dealer.

 When towing the unit on public roads, use flashing amber warning lights and a slow moving vehicle (SMV) identification emblem. Make sure the SMV placard is clearly visible to vehicles approaching from the rear.

Some localities prohibit the use of flashing amber lights. Local laws should be checked for all highway lighting and marking requirements.

Be a safe and courteous driver. Always yield to oncoming traffic in all situations, including narrow bridges, intersections, etc. Plan your route to avoid heavy traffic.

Be observant of bridge load restrictions. Do not cross bridges rated lower than the gross weight at which you are operating.

Make sure the wheel lift cylinder transport locks are installed, and the jack stand is in its storage position before transporting the unit.

When transporting the implement on rough or uneven surfaces, drive slowly to prevent bouncing and loss of contact of the front wheels and the ground.

## OPERATION SAFETY

### ⚠️ WARNING

 **Crush Hazard (Rolling Over)**  
Do not clean, lubricate, or make adjustments while the unit is moving.

 Never allow inexperienced or untrained personnel to operate the implement or tractor without supervision.



 **Enter And Exit Tractor**  
To avoid being run over, do not enter or exit tractor when it is moving. Avoid serious injury or death, from contact with rotating tires, by entering or exiting tractor only when it is completely stopped.

 **Safe Distance**  
Keep all bystanders, especially children, away from the tractor and implement during operation.

 **Overturn Hazard**  
Pick the most level route possible when transporting across fields. Avoid the edges of ditches, gullies, or steep hillsides. Be especially careful when turning on slopes with the wheels down. Never turn uphill with the wheels down except at slow speed and a low rate of turn. Never transport or operate this machine on steep slopes.

### SAFETY INSTRUCTIONS

 Periodically clear the unit of brush, twigs, or other materials to prevent buildup of dry, combustible materials.

  Visually check all fasteners for tightness or damage before and after operation. Repair immediately if required.

## Tractor Requirements

### ⚠️ WARNING

 **Tractor Owner/Operator Manual**  
Always refer to the tractor Operator's Manual to ensure compatibility and maximum safety. Be familiar with the location, settings, and function of the tractor controls before using this equipment.

### SAFETY INSTRUCTIONS

Do not use a tractor of more than the recommended HP to prevent damaging implement components.



## Tractor Safety Devices

If transporting or operating the tractor and implement near a public roadway, the tractor must be equipped with proper warning lighting and a Slow Moving Vehicle (SMV) emblem, which are clearly visible from the rear of the unit. Lights and a SMV emblem must be attached directly to the implement if the visibility of the tractor warning signals is obscured.

Never operate the tractor PTO with the PTO master shield missing or in the raised position.

## ROPS and Seat Belt

The tractor must be equipped with a Roll Over Protective Structure (ROPS) (tractor cab or roll-bar) and seat belt to protect the operator from falling off the tractor, especially during a roll-over where the driver could be crushed and killed.

Only operate the tractor with the ROPS in the raised position and seat belt fastened.



### WARNING



#### Rollover Hazard

To avoid serious injury or death from falling off tractor, equipment rollover, rollover, or crushing:

- 1) Use ROPS equipped tractor.
- 2) Keep ROPS locked in the UP position.
- 3) Only operate the equipment when seated in the tractor seat.
- 4) Always fasten seat belt when operating the tractor and Implement.

## Attaching to Tractor

### Prior to Connecting Unit

Make sure the unit is resting on the ground or the transport lock is securely installed over the wheel cylinder rod before attaching the unit to the tractor.

### Connecting to Tractor



### WARNING



#### Crush Hazard

Use care when attaching the unit to the tractor. Never place any part of your body under the tongue or hitch assembly. Do not allow anyone to stand between moving tractor and implement during hook-up operations.

## Unexpected Separation Hazard



If towing the unit with a drawbar, use only a certified, hardened drawbar pin with a retainer clip. Do not use homemade pins, bolts, or any other type of retaining device. Always install the retainer clip, making sure the hitch and unit are securely fastened to the tow vehicle.

Using a pin not intended for this type of towing can result in unexpected separation of the unit from the tow vehicle, resulting in equipment damage and personal injury.

## SAFETY INSTRUCTIONS

Connect implement hitch to the tractor properly.

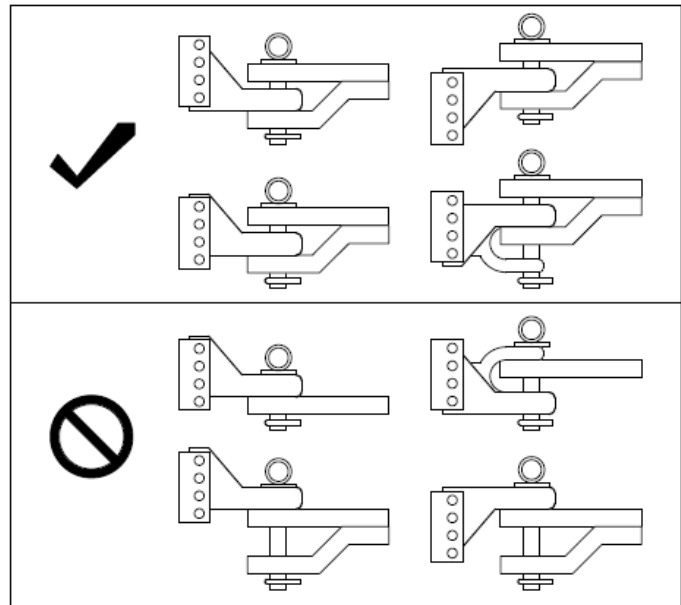

## Hydraulic Component Safety



### WARNING



#### High-Pressure Fluid Hazard

Before applying pressure to the system, make sure all components are tight and that the hydraulic lines, hoses, fittings, and couplings are not damaged.



#### Hydraulic Pressure

This unit operates with hydraulic pressures of 2500 to 3000 psi (170 to 205 bars).

## ⚠ WARNING

### High-Pressure Fluids



1. Check or tighten all connections BEFORE pressurizing system.



2. Release all pressure before removing hoses and/or valves by:

- a. Stopping engine .
- b. Holding hydraulic control levers in float or neutral position .



3. DO NOT use your bare hand to check for potential leaks . Always use a board or cardboard when checking for a leak .

Escaping hydraulic fluid under pressure, even a pinhole size leak, can penetrate body tissue, causing serious injury and possible death. If fluid is injected into your skin, it must be treated immediately by a doctor familiar with this type of injury.



Wear proper hand and eye protection when searching for a high-pressure hydraulic leak.

Use a piece of wood or cardboard as a backstop instead of hands to identify and isolate a leak .

If injured by a concentrated high-pressure stream of hydraulic fluid, seek medical attention immediately. Without immediate medical treatment, serious infection or toxic reaction can develop if hydraulic fluid penetrates the surface of the skin.



### Trapped Air Hazard

When installing, replacing, or repairing hydraulic system cylinders or parts, make sure that the entire system is charged and free of air before resuming operations . Failure to bleed the system of all air can result in improper machine operation, causing severe injury .



### High-Pressure Separation Hazard

Replace any worn, cut, abraded, flattened, or crimped hoses .



### Zero Pressure

Relieve pressure from the hydraulic system before servicing or disconnecting from the tractor.



### High-Pressure Hazard

Do not make any temporary repairs to the hydraulic lines, fittings, or hoses using tape, clamps, or cement . The hydraulic system operates under extremely high pressure and temporary repairs may fail suddenly and create a hazardous/ dangerous situation .

## ⚠ CAUTION



### Explosive Separation Hazard

Be sure all hydraulic pressure is relieved before disconnecting hydraulic lines or fittings between implement and the tractor hydraulic system.

## NOTICE

Make sure components in the hydraulic system are kept clean and in good working condition .

## MAINTENANCE SAFETY

### ⚠ WARNING



### Use Properly Rated Tools

Use sufficient tools, jacks, and hoists that have the capacity for the job .



### Crush Hazard

Use support blocks or safety stands rated to support the load when performing maintenance .

## SAFETY INSTRUCTIONS

Follow all operating, maintenance, and safety instructions found in this manual .



Understand the service procedure before performing the work . Keep area clean and dry .



Keep all parts in good condition and properly installed . Fix damage immediately . Replace worn or broken parts .



Do not leave tools lying on the unit .



Do not modify unit or safety devices . Do not weld on the unit . Unauthorized modifications may impair its function and safety .

If equipment has been altered in any way from the original design, the manufacturer does not accept any liability for injury or warranty .



Never replace hex bolts with less than Grade 5 bolts unless otherwise specified. In locations where Grade 8 bolts are used, Grade 8 replacements are required .



## SAFETY INSTRUCTIONS



Where replacement parts are necessary for periodic maintenance and servicing, genuine factory replacement parts must be used to restore the unit to original specifications.

The manufacturer will not accept responsibility for damages as a result of the use of unapproved parts.

### Tires Safety



## WARNING



### Explosive Separation Hazard

Do not attempt to mount a tire onto a wheel unless you have the proper equipment and experience to do the job. Failure to follow proper procedures when mounting a tire on a wheel can produce an explosive separation, which may result in serious injury or death.



### Explosive Hazard

Never weld or heat a wheel and tire assembly. The heat can cause an increase in air pressure, resulting in a tire explosion. Welding can structurally weaken or deform the wheel.



### Flying Objects Hazard

Inflating or servicing tires can be dangerous. Whenever possible, trained personnel should be called to service and/or mount tires.

When inflating tires, use a clip-on chuck and extension hose. Always stand to the side of the tire when inflating, and NOT in front of or over the tire assembly. Make sure the tires are inflated evenly.

## SAFETY INSTRUCTIONS



Always maintain the correct tire pressure. Do not inflate the tires above the recommended pressure.



Check tires for low pressure, cuts, bubbles, damaged rims, or missing lug bolts or nuts.



Keep wheel lug nuts or bolts tightened.



Always install replacement tires and wheels with appropriate capacity to meet or exceed the weight of the unit.

## Bolt Torque Requirements

It is extremely important to apply and maintain proper torque on all bolts. Use a torque wrench to assure the proper amount of torque is being applied to the fastener.

Start all bolts or nuts by hand to prevent cross threading.

Torque figures indicated in the chart are used for non-greased or non-oiled threads unless otherwise specified. Therefore, do not grease or oil bolts or cap screws unless otherwise specified in this manual. When using locking elements, increase torque values by 5%.

The chart gives correct torque values for various bolts and cap screws. Tighten all bolts to the torques specified in the chart unless otherwise noted. Check tightness of bolts periodically, using the bolt torque chart as a guide. Always replace hardware with the same Grade bolt.



## WARNING



### Equipment Failure

The torque value for bolts and cap screws are identified by their head markings. Replacing higher "Grade" bolts (Grade 5) with lower Grade bolts will lead to equipment failure and can result in injury or death. Always use replacement bolts with the same Grade markings as the removed bolt.

Bolt Diameter	Bolt Torque Specifications			
	Grade 5		Grade 8	
	N·m	ft.lbs.	N·m	ft.lbs.
1/4"	12	9	17	12
5/16"	25	19	36	27
3/8"	45	33	63	45
7/16"	72	53	100	75
1/2"	110	80	155	115
9/16"	155	115	220	165
5/8"	215	158	305	220
3/4"	390	290	540	398
7/8"	570	420	880	650
1"	850	630	1320	970

## Tire and Lug Torque Specifications

Tire Size	Ply Rating	Lug Size	Lug Torque (lb.ft.)
7.6 x 15	8 Ply	1/2"	80
9.5 x 15	8 Ply	1/2"	80
12.5 x 16	14 Ply	9/16"	70

## Welding Repairs



Before performing any type of welding repair to the implement, contact T.G. Schmeiser Co., Inc. for approval. Repair welding must be done with care and with procedures that may be beyond the capabilities of the ordinary welder.



### WARNING

#### Personal Injury Hazard



Repairs or modifications to the implement can result in serious injury or death should these repairs fail.

### NOTICE

Anyone performing a welding repair should be certified in accordance to the American Welding Society (AWS) standards.

## STORAGE SAFETY



### WARNING



#### Hazard And Information Signs

Replace any missing or hard-to-read safety signs. Safety sign placement and part numbers can be found in the Nomenclature section of this manual.



#### Damaged Parts Hazard

Do not use this unit if it is in need of repair. If you believe the unit has a defect which could cause damage, injury, or death, you should immediately stop using the unit.

## SAFETY INSTRUCTIONS



Store the implement in an area away from human activity.



Do not permit children to play on or around the stored unit at any time.



Block the wheels to prevent the implement from rolling.



When using compressed air to clean implement, wear safety glasses.

## DISPOSAL OF EQUIPMENT AT END OF USEFUL LIFE

The T. G. Schmeiser implement has been designed for the specific purpose of conditioning the ground in agricultural applications. When this unit is no longer capable of doing its designed purpose, it should be dismantled and scrapped. Do not use any materials or components from this unit for any other purpose.

**SAFETY MARKING AND LIGHTING**

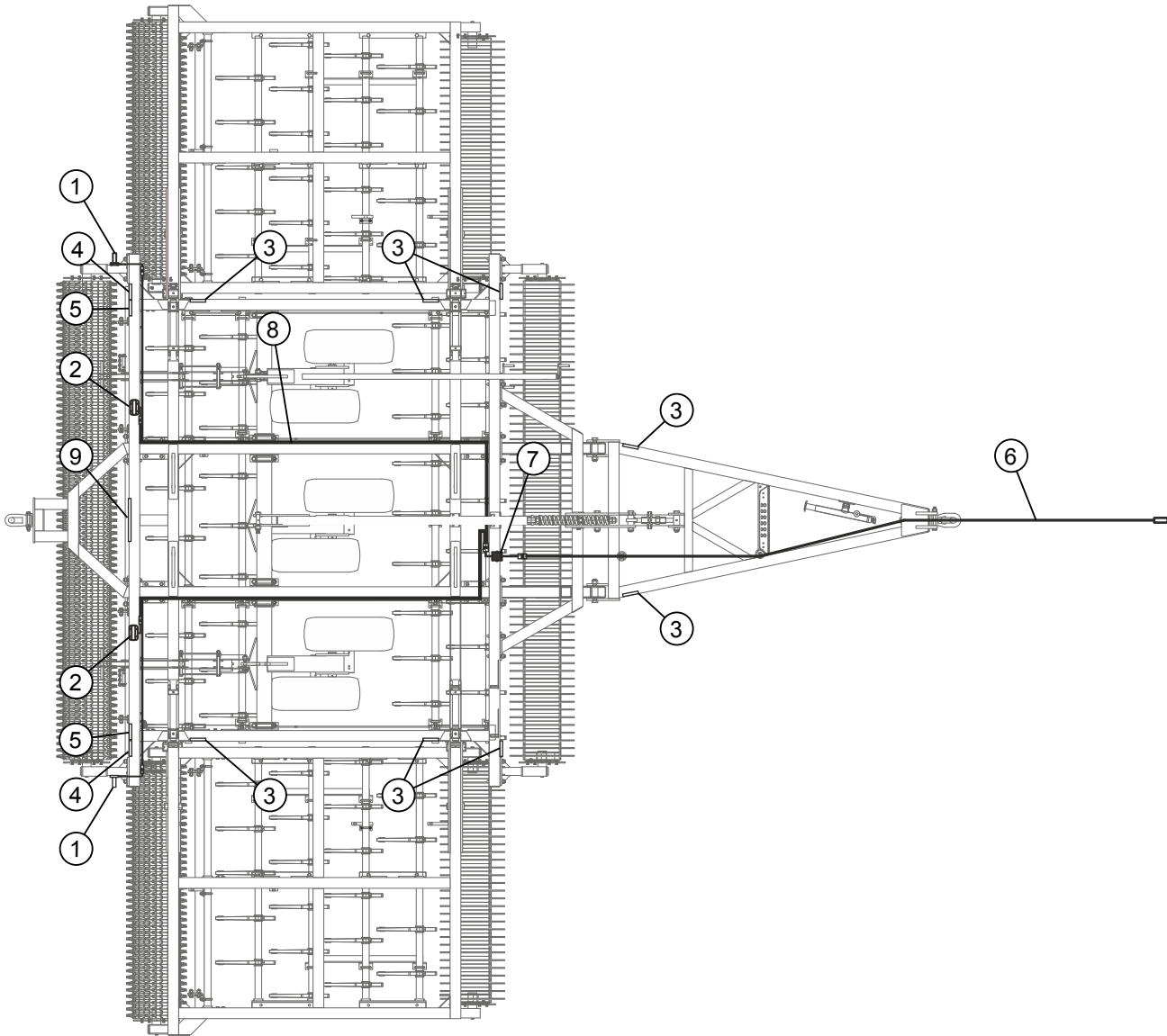

##	Part Number	Description	Q'ty
1	GLT-LSDY	Lamp, Surface Mount Double Yellow	2
2	GLT-LSSR	Lamp, Surface Mount Single Red	2
3	D-2X9RY	Reflective Tape, Yellow	8
4	D-2X9RR	Reflective Tape, Red	2
5	D-2X9FL	Fluorescent Tape, Orange	2
6	GLT-FH30	Front Harness, 30 Ft. Long	1
7	GLT-FCM	Flasher Control Module	1
8	GLT-HW5050	Rear Wishbone Harness 50 Ft.-50 Ft.	1
9	GMB-SMVSN	Slow Moving Vehicle Sign	1

**SAFETY SIGNS AND DECALS**

**Safety Signs**

Item	Part Number	Description	Qty.
1	D48X038RTM	Read the Manual	1
2	D48X038CRR	Crush / Rollover Hazard	1
3	D48X064HPF	High Pressure Fluids	1
4	D28X0048ECH	Electrocution Hazard	2
5	D28X048CRH	Crush Hazard	4
6	D28X048PPT	Pinch Point	6
7	D28X048RBW	Transport Lockout	5
8	D76X040SGB	Transport Safety Chain	1
9	-----	Head Injury Caution (part of Decal Kit)	4
10	-----	Lockout Safety Pin (part of Decal Kit)	3
11	-----	Lockout System Operation (part of Decal Kit)	3
12	D60X048RBW	Attention S-Tines	2
13	-----	Hose Storage Decal (part of Decal Kit)	1
14	-----	Manifold Decal (part of Decal Kit)	2
15	DFEMALOGO1	FEMA	1
16	D48X48QR	Scan to Access Online Manual	1
17	D32X048RBC	Made in the USA	1
18	D52X272BLK	Schmeiser	
19	D48X144T&B	Till An' Bedder Decal	4
20	D104608BLK	Schmeiser with Web Site	4
21	D28X048SCE	Sharp Object Hazard	4

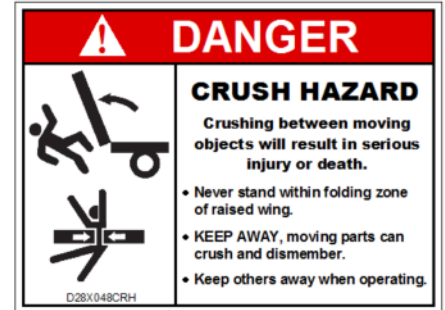

5.

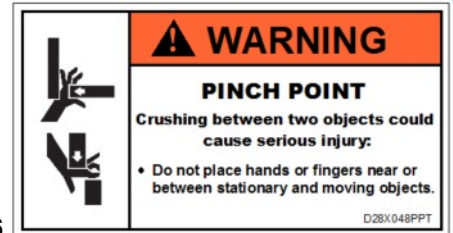

6.



7.



8.



9.

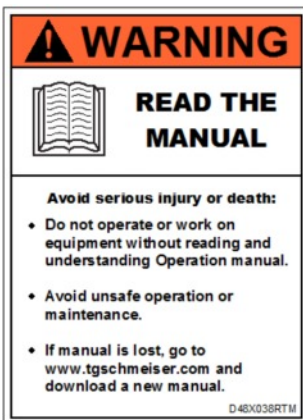

1.

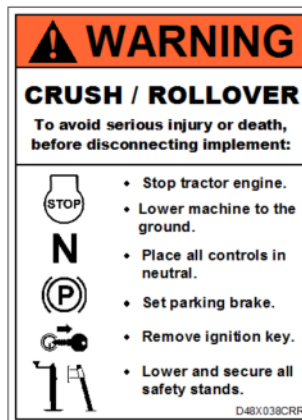

2.

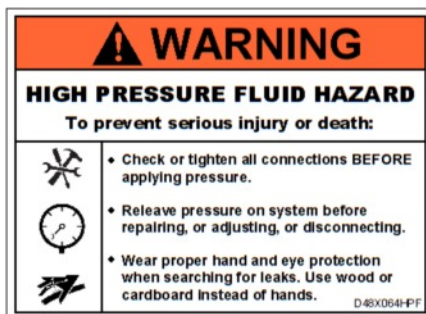

3.

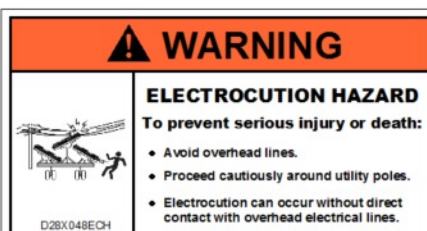

4.



10.

**CAUTION**  
TO AVOID EQUIPMENT DAMAGE:  
• ALL THREE LOCKS MUST BE IN FIELD POSITION PRIOR TO LOWERING UNIT

**FIELD USE**

**SAFETY TRANSPORT**

**WARNING**  
TO PREVENT INJURY:  
• ALL THREE LOCKS MUST BE IN TRANSPORT POSITION PRIOR TO TRANSPORTING

11.

**ATTENTION**



THIS MACHINE MUST BE FULLY RAISED ON WHEELS BEFORE S-TINES MAY BE ROTATED.

D60X048RBW

12.

WINGS WHEEL AXLE LEVEL. PIPE S-TINES

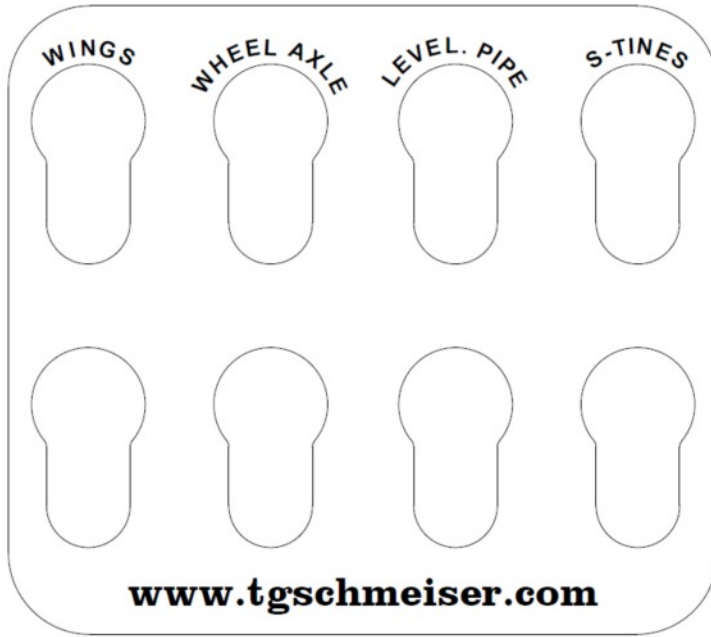

www.tgschmeiser.com

13.

WHEEL AXLE

LEVEL. PIPE

S-TINES

14.



**FEMA**  
FARM EQUIPMENT  
MANUFACTURERS  
ASSOCIATION

15.

**SCHMEISER**  
www.tgschmeiser.com

D52X272BLK

18.

SCAN TO ACCESS  
ONLINE PARTS MANUALS



T. G. SCHMEISER CO., INC.  
www.tgschmeiser.com

D41X4Q2R

16.

MADE IN THE USA



**T. G. SCHMEISER**  
SELMA, CALIFORNIA

17.

D32X048RBC



**TILL AN' BEDDER**

19.

**SCHMEISER**  
www.tgschmeiser.com

20.



## ASSEMBLY AND OPERATION



### WARNING



#### Understand Safety Procedures!

Read and understand all safety procedures described in this manual before performing any work on or around the implement.

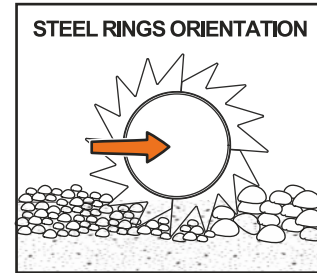

### Assembly Instructions

#### THE FOLLOWING TOOLS ARE NEEDED:

1. Overhead hoist or forklift.
2. Impact gun or socket wrench with different size sockets.
3. 3/16" allen wrench.
4. Pry bar

#### PROCEDURE:

1. Select a smooth, level piece of ground of approximately 50' x 50' to assemble the SCHMEISER 4-Bar Folding Till An' Bedder. Unhook Folding Till An' Bedder from shipping stands and place folded Till An' Bedder on the ground.
2. Move Roller Arms from shipping position to in-use position. Mount Roller Arms to the front and to the rear of the Main Frame. Install 7/8" NF Square U-bolts with lock washers and hex nuts, hand tighten only – see page 28 for details.
3. Mount Main Frame Front Ring Roller to the front of the machine using M18-2.5 X 70 mm Hex Head Bolt with flat washers and lock washers. Tighten all bolts. For packing, front ring teeth should aim down. For tilling, front teeth should aim up. For rollers with Steel Rings, ring teeth should always aim down.

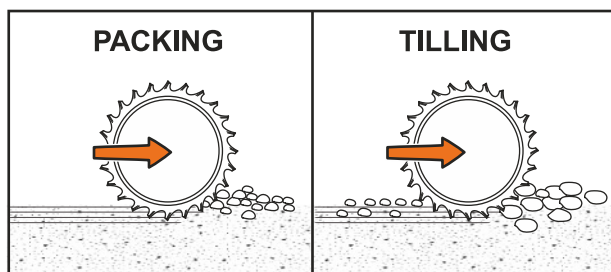

4. Mount Main Frame Rear Ring Roller to the rear Roller Arms using M18-2.5 X 70 mm Hex Head Bolt with flat washers and lock washers. Tighten all hex bolts. Once the rear roller is mounted, tighten Roller Arm bolts.
5. Attach Front-to-Rear Level Assembly to the center cylinder anchor on the Wheel Axle. Connect Trunnion to two Level Link Plates. Install spacer between Level Link Plates. Refer to p. 35 for reference.
6. Unfold Folding Till An' Bedder and level wings with the Main Frame.
7. Mount all Wing Rollers to the Wing Frames, using M18-2.5 X 70 mm Hex Head Bolts with flat washers and lock washers. Rear rollers should be 6" longer than front rollers. Tighten all bolts. Ensure that the ring teeth are aiming in the same direction on all ring rollers.
8. Install Wheel Axle lockout systems in place. Refer to drawings on page 40 for details.
9. Attach Front Frame with mounted Pull Frame to the front of the Main Frame. Refer to assembly drawing on page 27 for details and correct placement. Connect Front Frame and Main Frame using 3/4" x 2-1/2" NC Cap Screws with Lock Washers and Hex Nuts and 7/8" NF U-Bolts with Lock Washers and Hex Nuts. Ensure that center of the Main Frame lines up with center of the Front Frame. Tighten all fasteners.
10. Attach the ACME Turnbuckle to the Pull Frame and the Front-to-Rear Level Links using (2) 1-1/4" x 7" Gr.8 bolts and nylon lock nuts.
11. Attach Jack Stand to the Pull Frame.
11. Connect all safety lighting components - harnesses, flasher control module, and lamps. Check all connections.

12. Install Hose Holders on the Pull Frame and connect Lead Hoses to Hydraulic Manifold and tractor, and front safety lighting harness to tractor.
13. **BEFORE ENGAGING ANY HYDRAULIC CYLINDERS, ENSURE THAT NO ONE IS ANYWHERE NEAR THE IMPLEMENT OR TRACTOR.** Ensure that there are no overhead and/or other obstructions. All hydraulic lines must be free of debris and air and completely full of hydraulic fluid prior to field operation. Extend and retract rear leveling pipe cylinders and S-Tine cylinders until smooth operation is achieved. Lift and lower entire unit completely several times until all cylinders work as intended. Always raise unit fully off the ground prior to folding or unfolding wings. Take special care when unfolding wings. Fold and unfold wings until unit works smoothly.

\* *NOTE: 4-Bar Folding Till An' Bedder comes with all hydraulic cylinders preinstalled. Also, wings, S-tines and wheel axle are preassembled on the main frame for shipping.*

### Attaching to Tractor

1. Raise the jack stand until the tongue is at the height of the tractor drawbar.
2. Connect the hitch of the unit to the tractor. Attach the safety chain to the tractor's drawbar cage.

*NOTE: If a drawbar pin is used, it should be an OEM certified pin and retainer clip. On Category 3 pentel hitches use a 1-1/2" (38 mm) pin.*

3. Raise the jack stand and rotate into its storage position.
4. Connect the hydraulic hoses to the proper ports on the tractor.

### Adjusting the 4-Bar Folding Till an' Bedder

The Schmeiser 4-Bar Folding Till an' Bedder is a versatile implement that can be configured for a variety of field conditions. Properly adjusted, it can be used to achieve a wide variety of desired results. The following instructions are offered as a guide.

Soil type, moisture content, tractor HP, speed, depth, and roller types all greatly affect final finish. It is recommended that S-Tines and Leveling Pipe depths be adjusted for each type of crop and specific soil conditions.

### Prior to adjustment:

1. Ensure that unit is clean and free of debris.
2. Perform adjustments on firm, level surface.
3. Attach Till An' Bedder to tractor. Refer to "Attaching to Tractor" on p.—.
4. Ensure that unit is in the fully raised position with the safety lockout bars in place.

### Front-to-Rear Level Adjustment

1. Remove on-board adjustment rod from storage location
2. Insert adjustment rod into turnbuckle body

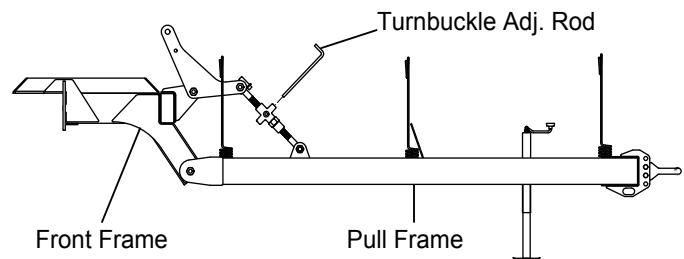

3. Rotate turnbuckle body until unit is level from front to rear.
4. Replace adjustment rod to storage location to prevent unwanted turnbuckle rotation.
5. If using turnbuckle to adjust pressure on rollers, check Front to Rear Level springs and readjust accordingly using two hex nuts at the end of threaded rod. Springs should be snug, but never fully compressed.

*NOTE: If adjusted properly, unit will remain level during all phases of operation.*

*NOTE: Turnbuckle can be adjusted so that there is more pressure on the front rollers or on the rear rollers.*

*NOTE: 4-Bar Folding Till An' Bedder bearings do not require lubrication during the initial assembly, as they come prelubed from the factory. After 40 hours of service, bearings should be greased every 8 to 10 hours.*

### Operating Instructions

1. Make sure the 4-Bar Folding Till An' Bedder is properly attached to the tractor before beginning work. Inspect the condition of rings and S-Tines and the overall 4-Bar Folding Till An' Bedder for potential problems or damage. Do not use the unit if it needs repairs of any type.



2. Clear the area of bystanders, especially small children. Make sure that you can clearly see and identify passersby, steep slopes, ditches, drop-offs, power lines, debris, and foreign objects. If you are unable to clearly see these type of items, discontinue operating the 4-Bar Folding Till An' Bedder.
3. Know the location of all underground cables, pipelines, and other hazards in the area. Also make certain that all irrigation heads, utility outlets, and other obstacles are properly marked.
4. Watch for low hanging limbs, power lines, and other overhead obstacles while you are operating. Use care to avoid hitting these items.
5. Do not operate the 4-Bar Folding Till An' Bedder, or drive the tractor into material that is burning, or areas that recently burnt and may contain hot spots. Tire damage can occur when driving over hot material. Oil and grease on the tractor and the implement could ignite resulting in equipment destruction.
6. Using the tractor's hydraulic controls, raise the unit to remove the load from the wheel axle lockout bar.
7. Push all three rear lockout system handle tubes forward to flip lockout bars open from the hydraulic cylinder rods and secure in the field position using pins with chains welded to the main frame.
8. Lower unit to the desired depth.
9. Proceed forward at desired speed. Ideal speed may vary depending on soil conditions, the 4-Bar Folding Till An' Bedder will immediately start working soil.
10. Adjust speed, S-Tines depth, rollers load to achieve desired finish. Refer to p.18 for proper procedures.

### **Operating Instructions with Secondary Unit Attached to Rear Trail Hitch.**

Ensure the following order of operation to avoid equipment damage.

#### **To Lower Units into Field Use:**

- Remove all three safety pins and slide (push) all three lockouts to field position. Reinstall safety pins in place.
- Lower Till An' Bedder first
- Lower trailing unit last.

#### **To Raise Units During Field Use:**

- Raise trailing unit first.
  - Raise Till an' Bedder last.
- OR
- Raise both units simultaneously.

#### **To Raise Units for Transport:**

- Remove safety pins and slide (pull) all three lockouts to transport position. Reinstall safety pins in place.
- Raise trailing unit first.
- Raise Till an' Bedder last. Ensure that all three lockouts are properly seated on cylinders.
- Retract transport cylinders slightly so that lockouts are making contact with cylinders.

### **Towing Instructions Without Secondary Unit**

To set Till an' Bedder into transport position:

1. Fold wings up.
2. Fully extend transport cylinders.
3. Raise leveling pipes and S-Tines to "up" position
4. Remove all three rear lockout pins from lock holes.
5. Pull all three rear lockout handle until lockout bars fall in place to lock cylinder rods.
6. Carefully retract transport cylinders until lockouts make contact with both, the body and rod end of the cylinders.
7. Reinstall lockout lock pins in lock holes.
8. Refer to towing safety instructions on p. 9.





### **Detaching From Tractor**

1. Park the tractor, place the transmission in park or neutral, and apply the parking brake. Shut down the engine, relieve all hydraulic pressure, and remove the key before exiting the tractor.
2. Block the wheels to prevent movement.
3. Remove the jack from its storage location and secure it to the hitch by fully inserting the locking pin through the jack and the hitch bracket. Use the jack to raise the hitch to the height needed to disconnect it from the drawbar.
4. Disconnect the hydraulic hoses from the tractor. Coil the hoses and store them on the pull frame hose storage bracket.
5. Disconnect the hitch safety chain.
6. Remove the hitch pin and drive the tractor away from the implement.

### Initial Setup Checklist

Efficient and safe operation of the implement requires that every user read and understand the operational instructions and all related safety instructions outlined in this manual.

This checklist is provided for the user/owner. It is important for both personal safety and to maintain the mechanical condition of the implement that this checklist is followed.

Initial Setup Checklist (prior to using for the first time)	
Location	Task
	Make sure the Implement is properly attached to the tractor. Refer to "Attaching to Tractor" on page 18.
	Make sure all hardware is properly installed and tightened. Refer to "Maintenance" on page 21.
	Check the condition of the rings, S-Tines, and bearings for wear, hydraulic hoses for leaks. Replace if necessary.
	Lubricate all grease fittings. Refer to "Lubrication Points" on page 21.

### Implement Break-In

Although there are no operational restrictions on the Implement when used for the first time, it is recommended that the following mechanical items be checked:

1. After 1/2 hour of operation:
  - a. Check all fasteners and tighten if necessary.
  - b. Make sure that the ring rollers and S-Tines are in good condition.
2. After 10 hours of operation:
  - a. Go to the normal servicing and maintenance schedule, as defined in the Maintenance Section.

### MAINTENANCE

## ⚠ WARNING



### Understand Safety Procedures!

Read and understand all safety procedures described in this manual before performing any work on or around the implement.

### Lubrication Points

Add grease to the locations shown.

#### Wheel Hub Bearings

Grease once per season – inspect bearings and races for wear and replace if necessary.

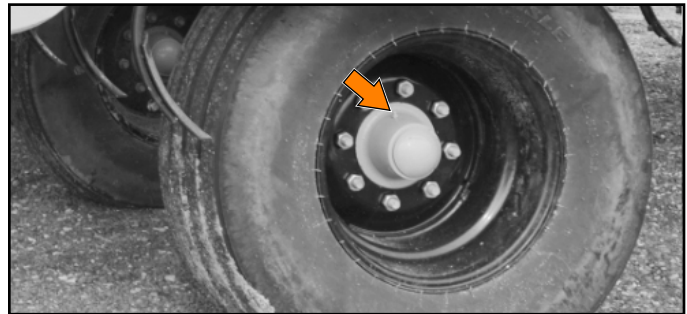

#### Turnbuckle and Linkages

Grease once per season.

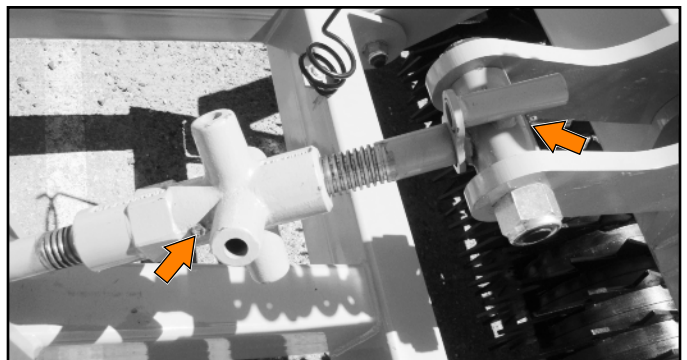

### Ground Engaging Components

Ground engaging components are subject to abrasion and wear. Excessively worn components will require replacement.

### Roller Rings

Replace rings if they are excessively worn or damaged.

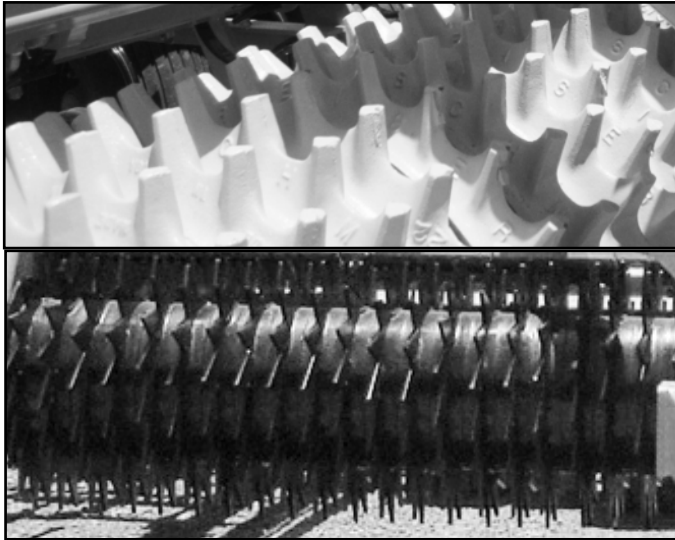

### Steel Rings Scrapers (Optional)

Adjust down as scrapers wear, and replace scrapers if they are excessively worn or damaged.

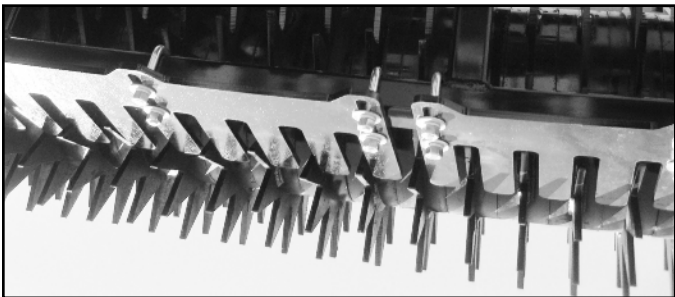

### S-Tines

Carefully inspect S-Tines and S-Tine points before operation. Replace the S-Tine points when both sides are worn out. Replace S-Tines if damaged.

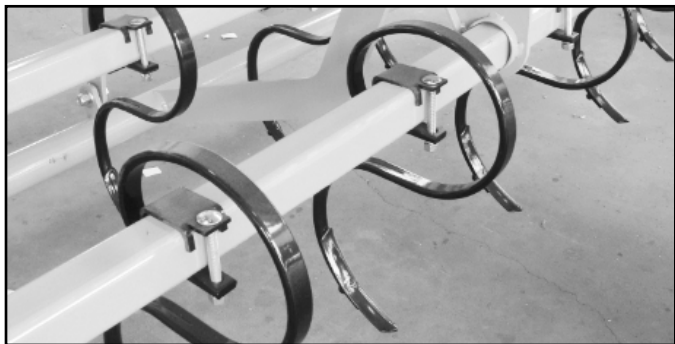

### Service Items

#### Tires

Check tire pressure and set to tire manufacturer's recommended specifications. Inspect the tires for wear and/or damage. Make sure the wheel lugs are tightened to the proper torque.



#### Front to Rear Level Springs

Visually inspect and replace when springs are overly worn or damaged.



#### Hydraulic Hoses

Inspect all hydraulic hoses and fittings for leaks or signs of wear. Replace any that are overly worn or damaged.





**MAINTENANCE SCHEDULE**

Hours and Serviced By																				
<b>Maintenance</b>																				
<b>Before Each Use</b>																				
Ensure that all fasteners are tight, and all pins are secured in place.																				
Inspect the frame for structural fractures.																				
Make sure all warning decals are in place and legible.																				
Inspect all hydraulic hoses and fittings for leaks or signs of wear.																				
Check all roller rings and S-Tines for wear and damage. Replace if necessary.																				
Lubricate zerk fittings on ring roller bearings with a good general purpose grease.																				
<b>Every 50 Hours or Weekly</b>																				
Perform the Daily Maintenance schedule.																				
Lubricate zerk fittings on wing hinges with a good general purpose grease.																				
Check tire pressure and set to tire manufacturer's recommended specifications. Inspect the tires for wear and/or damage. Make sure the wheel lugs are tightened to the proper torque. Refer to "Tire and Lug Torque Specifications" on page 13.																				
<b>Every 1000 Hours or Annually</b>																				
Perform the Daily Maintenance schedule.																				
Perform the Weekly Maintenance schedule.																				
Lubricate zerk fittings on the transport wheel bearing hubs with a good quality wheel bearing grease. Fill each cavity just until resistance is felt. Do not force grease past the seals.																				
Remove debris and clean the entire implement with compressed air or a pressure washer.																				
Remove rust and apply a coat of paint to frame surfaces where the paint has been worn off or damaged.																				

**STORAGE**

**Storage Preparation**

After Folding Till An' Bedder X 4-Bar field work is completed for a season, perform the following maintenance procedures before storing the implement.

1. Check all bolted connections. Ensure that the fasteners are tight, and all retaining pins are secured in place with appropriate retaining clips.
2. Check the tire pressure and set to the tire manufacturer's recommended specification. Inspect the tires for wear and/or damage. Make sure the wheel lugs are properly tightened. Refer to "Tire and Lug Torque Specifications" on page 13.
3. Inspect the frame for structural fractures and inspect rings for excessive wear or damage. Replace if needed.
4. Check all the bearings for signs of seal damage or excessive wear.
5. Inspect all the hydraulic hoses and fittings for leaks or signs of wear.
7. Make sure all the warning decals are in place and legible. Replace any worn decals as needed.
8. Remove debris and clean the entire implement with compressed air or low pressure water.



## NOTICE

To help prevent damage, avoid spraying air, water, steam, or cleaning solvents directly at the bearings and seals.

9. Lubricate all grease fittings on the frame members with a good general purpose lithium grease. Refer to "Lubrication Points" on page 21 for the location of the fittings.
10. Add grease to the fittings on the transport wheel bearing hubs with a good quality wheel bearing grease. Fill each cavity just until resistance is felt. Do not force grease past the seals.
11. Apply a thin layer of grease or rust preventative to all exposed metal surfaces of the cylinder rods.
12. To help prevent corrosion, remove rust and apply a coat of paint to frame surfaces where paint has been worn off or damaged.

### Placing in storage

1. Raise the implement, place in the transport mode, and install the transport lock.
2. Move the Folding Till An' Bedder X 4-Bar to a storage area with a firm and level base to prevent it from tipping or sinking into the ground. For best results, always store the implement in a dry, protected location. Leaving this implement unprotected will shorten the service life.
3. Disconnect all hydraulic hoses, and unhitch the implement from the tractor. Refer to "Detaching From Tractor" on page 20.
4. Store the implement with the transport wheels extended in the transport mode and the lockout bars installed over the cylinder rods. Do not leave the tractor attached to the implement while in storage.

### Removing From Storage

Each season, perform the following inspection and maintenance before using the unit.

1. Read the operator's manual to review all safety, operational, and maintenance procedures.

**Note:** Store the operator's manual in the document storage canister located on the front frame.

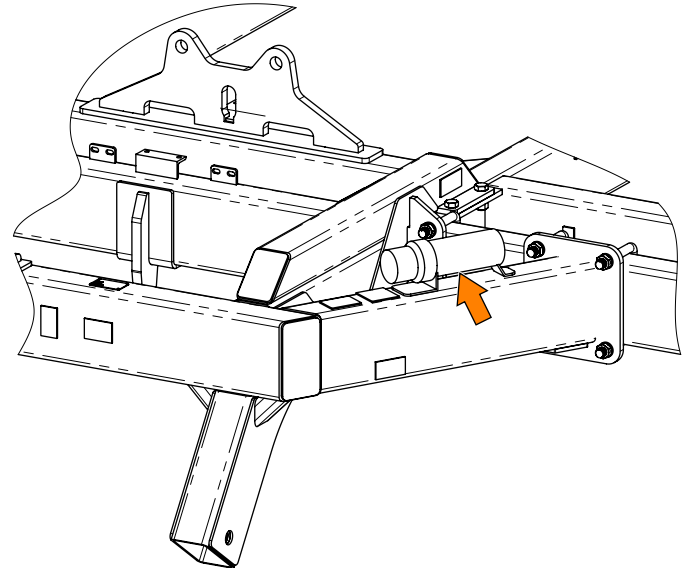

2. Perform any recommended maintenance that was not completed when the implement was put into storage.
3. Visually inspect the implement for wear or damage.
4. Check the tire pressure and set to the tire manufacturer's recommended specification. Inspect the tires for wear and/or damage.
5. Inspect all the hydraulic hoses and fittings for leaks and signs of wear or damage.
6. Make sure all the warning decals are in place and legible. Replace any damaged or missing decals.
7. Hitch the implement to a tractor and connect all hydraulic hoses. Refer to "Attaching to Tractor" on page 18. Place the implement in an area clear of overhead obstructions or power lines. Cycle the hydraulic system circuits to phase (synchronize) the hydraulic cylinders, verify proper operation, and check for leaks.

COMPONENTS NOMENCLATURE

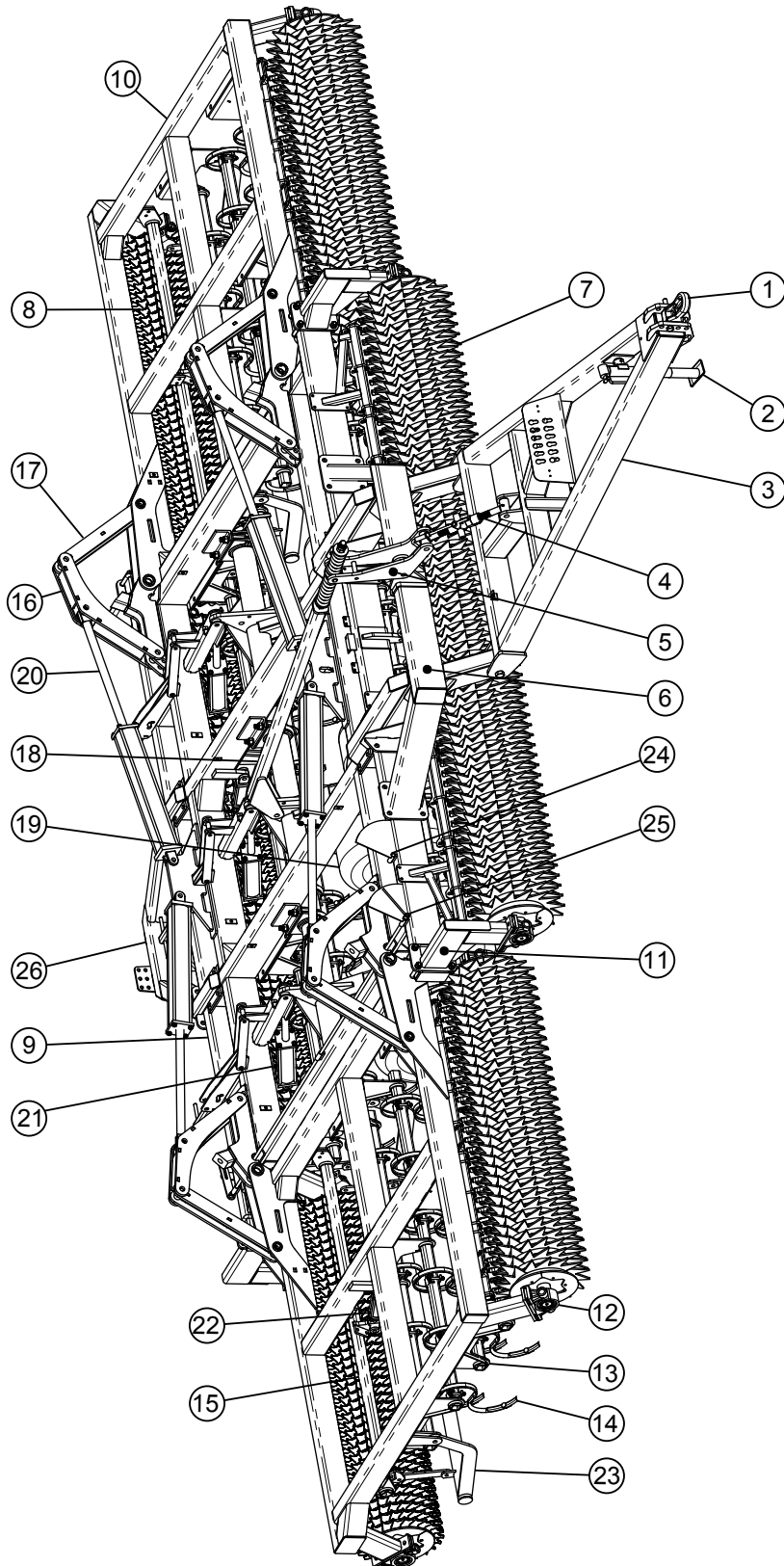

## COMPONENTS NOMENCLATURE (Continue)

### Ordering Parts

We manufacture a quality product that requires very little maintenance or repair. However, should a part break or become damaged, our knowledgeable staff can make sure you receive the part(s) to put your unit back into operation.

Item	Part Number	Description	Qty.
1	GMB-HITCHCA3H	Perfect Hitch CA3 Heavy	1
2	GJK-5KTW15	Jack Stand 5000# Capacity, Top winding	1
3	FTB4-00A100	Pull Frame	1
4	DTH-H	Front Turnbuckle Assembly	1
5	FTB4-00B200	Front to Rear Level Link Plate	2
6	FTB4-00D000	Front Frame	1
7	-----	Main Frame Front Roller (see p.— for all models)	1
	-----	Wing Front Roller (see p.— for all models)	2
8	-----	Main Frame Rear Roller (see p.— for all models)	1
	-----	Wing Rear Roller (see p.— for all models)	2
9	FTB4-15F000	Main Frame 15 Ft. (for 30 Ft. Units)	1
10	FTB4-75G000	Wings 7.5 Ft. (Pair)	1
11	FTB4-00J200	Roller Arm	4
12	553389	Roller Trunnion Bearing Assembly	12
13	FTB4-00K000	S-Tine Bar Hanger	20
14	GST-50125S	1/2" X 1-1/4" S-Tine (includes point and hardware)	Varies
15	FTB4-15Q101	S-Tine Bar / Lift Axle for 15 Ft. Main Frame	5
	FTB4-75Q102	S-Tine Bar / Lift Axle for 7.5 Ft. Wings	10
16	FTB4-00H100	Wing Linkage L-Link	4
17	FTB4-00H200	Wing Linkage Straight Link	4
18	FTB4-00B100	Front to Rear Level Bar (see p.— for details)	1
19	GWT-121614	12.5 X 16 14 Ply Tire with Wheel Assembly	6
20	GHC-50300T	5" X 30" Tie Rod Wing Hydraulic Cylinder	4
21	GHC-40160T	4" X 16" Tie Rod Wheel Axle Hydraulic Cylinder	3
22	-----	Series Cylinders for Leveling Pipe / S-Tines (see Hydraulic Diagram for part numbers)	—
23	FTB4-15N100	Leveling Pipe for 15 Ft. Main Frame	1
	FTB4-75N200	Leveling Pipe for 7.5 Ft. Wings ( Pair)	1
24	-----	Depth Indicator for S-Tines (see p. — for details)	1
25	-----	Depth Indicator for Leveling Pipe (see p.— for details)	1
26	FTB4-RTH	Rear Trail Hitch Kit (Optional)	1



**Pull Frame Assembly**

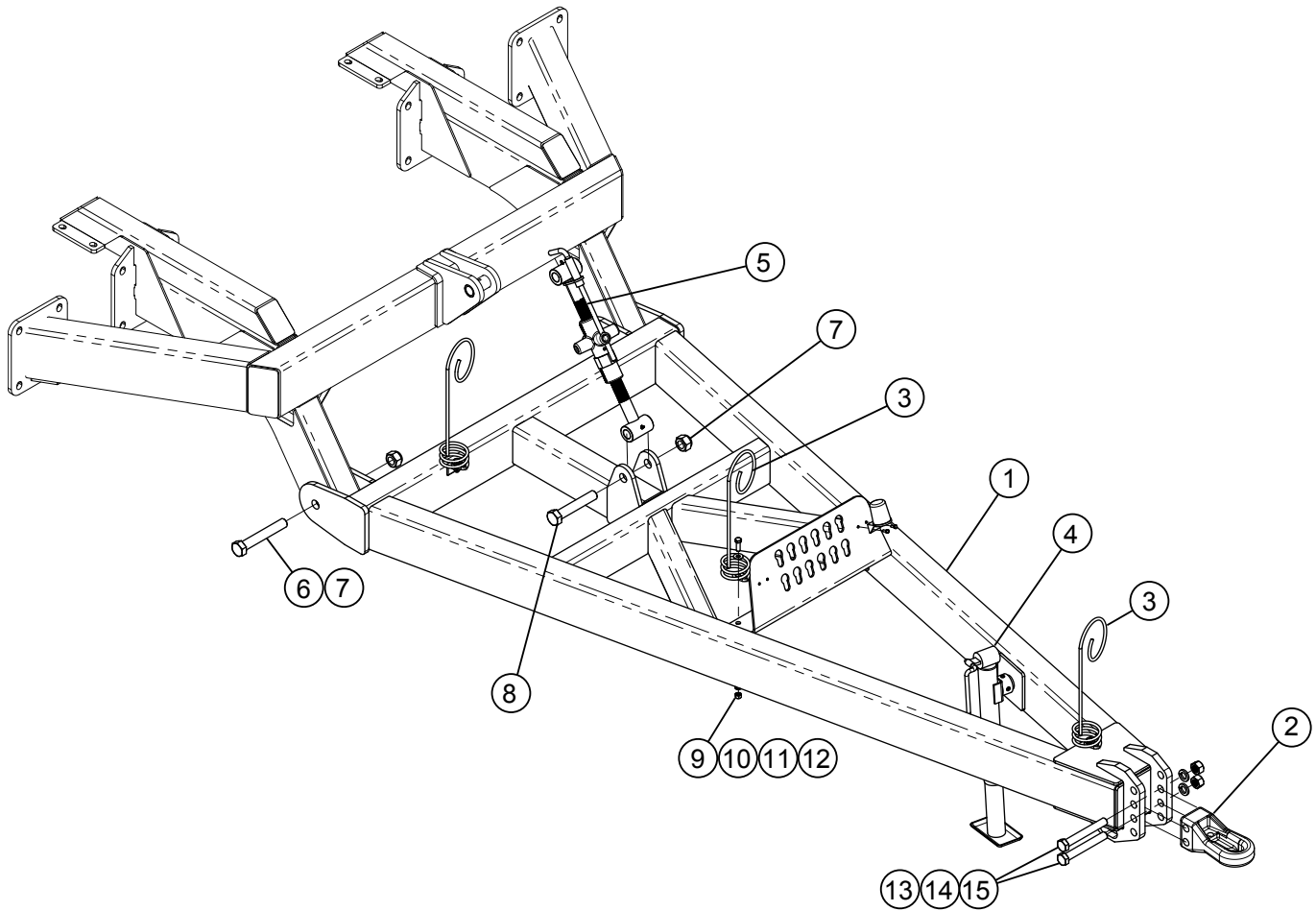

Item	Part Number	Description	Qty.
1	FTB4-00A100	Pull Frame	1
2	GMB-HITCHCA3H	CA 3 Heavy Perfect Hitch	1
3	GHD-HHOLD1	Hose Holder Long	3
4	GJK-5KTW15	Top Winding Jack Stand 5000# Capacity	1
5	DTH-00H000	Front Turnbuckle Assembly	1
6	CSNC520128	1-1/4" X 8" Gr.5 NC Cap Screw	2
7	NYNUT-20NC	1-1/4" NC Nylon Lock Hex Nut	2
8	CSNC820112	1-1/4" X 7" Gr.8 NC Cap Screw	1
9	CSNC508024	1/2" X 1-1/2" Gr.5 NC Cap Screw	3
10	LWASHER-08	1/2" Lock Washer	3
11	FWASHER-08	1/2" Flat Washer	3
12	HXNUT-08NC	1/2" NC Hex Nut	3
13	CSNC516128	1" X 8" Gr.5 NC Cap Screw	2
14	LWASHER-16	1" Lock Washer	2
15	HXNUT-16NC	1" NC Hex Nut	2

**Front Frame Assembly**

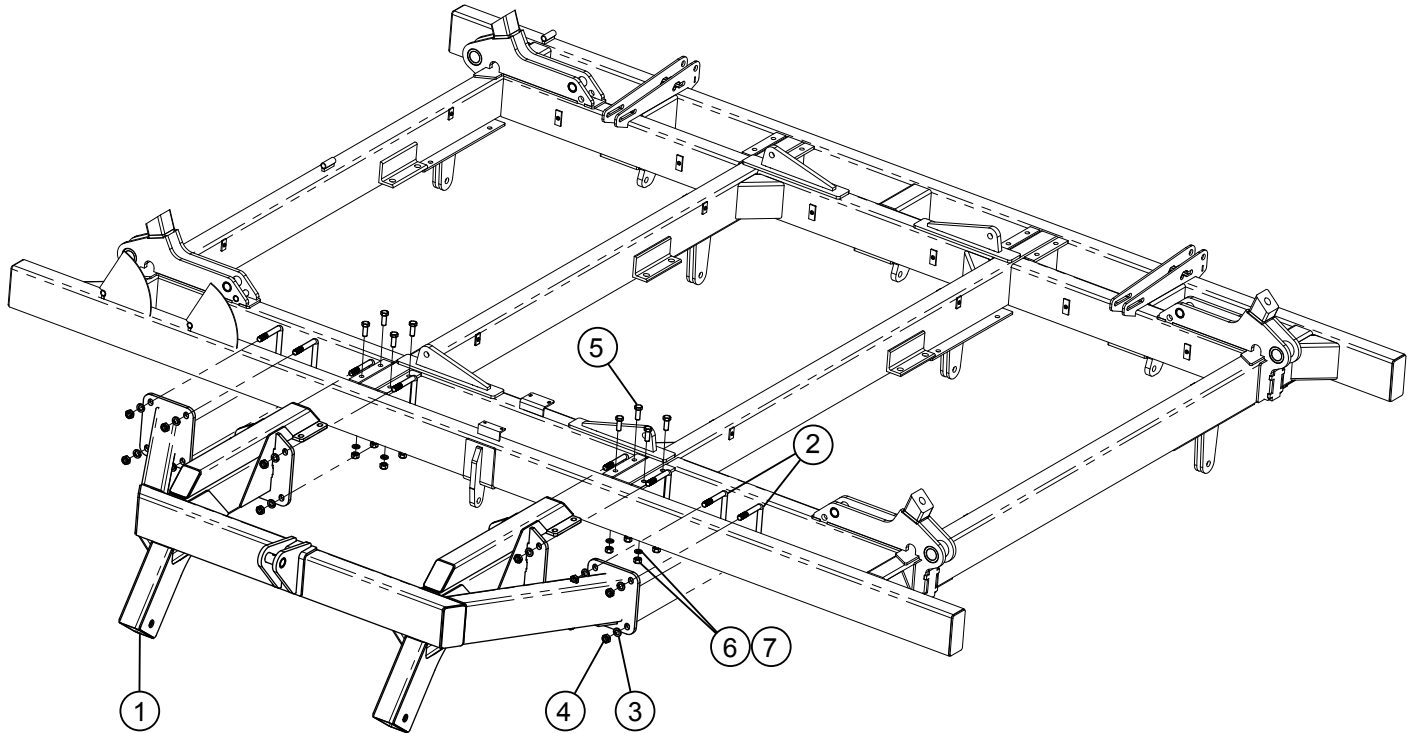

Item	Part Number	Description	Qty.
1	FTB4-00D000	FTB4 Front Frame	1
2	UBNF14128S	7/8" NF Square U-Bolt	8
3	LWASHER-14	7/8" Lock Washer	16
4	HXNUT-14NF	7/8" NF Hex Nut	16
5	CSNC512032	3/4" X 2" Gr.5 Cap Screw	8
6	LWASHER-12	3/4" Lock Washer	8
7	HXNUT-12NC	3/4" NC Hex Nut	8

## Main Frame Roller Leg and Roller Assembly

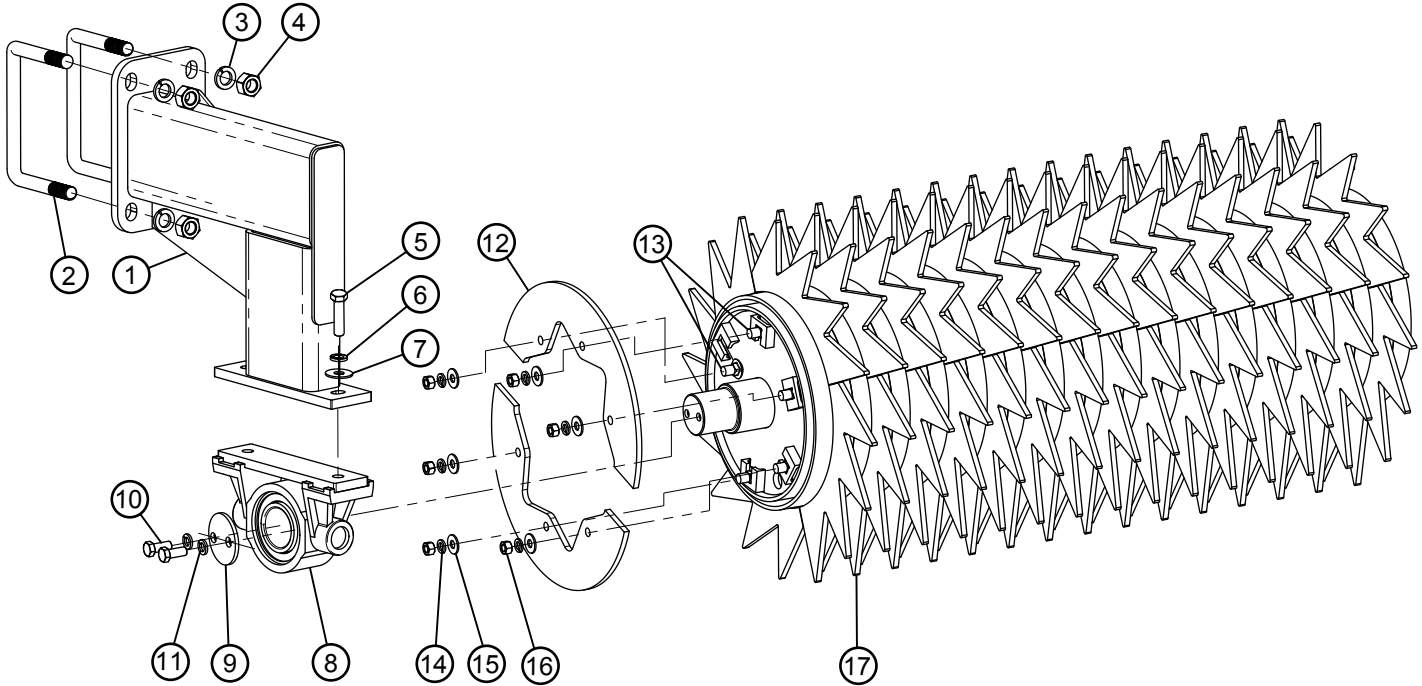

Item	Part Number	Description	Qty.
1	FTB4-00J200	Roller Arm	4
2	UBNF14128S	7/8" NC U-Bolt	8
3	LWASHER-14	7/8" Lock Washer	16
4	HXNUT-14NC	7/8" NC Hex Nut	16
5	212508	M18-2.5 X 70 mm Hex Head Bolt	8
6	LWASHER-12	3/4" Lock Washer	8
7	FWASHER-12	3/4" Flat Washer	8
8	-----	Bearing Assembly (see p. 29 for details)	2 / roller
9	TPR-43A005	Trunnion Thrust Plate (units 2021 and newer w / two hole shafts)	2 / roller
	TPR-43A004	Trunnion Thrust Plate (units 2020 w / one hole shafts)	2 / roller
10*	CSNC508028	1/2" X 1-3/4" Gr.5 NC Cap Screw	4 / roller
11*	LWASHER-08D	1/2" Disc Lock Washer	4 / roller
12	TPP3220	Ring Roller Retainer Plate 14/20 and 14/24S Rings	4 / roller
	TPP3221	Ring Roller Retainer Plate 16/22 Rings	4 / roller
13	CBNC510020	5/8" X 1-3/4" NC Carriage Bolt	12/roller
14	LWASHER-10	5/8" Lock Washer	12/roller
15	FWASHER-10	5/8" Flat Washer	12/roller
16	HXNUT-10NC	5/8" NC Hex Nut	12/roller
17	-----	Ring Roller (see p.30 for all ring options)	----

### Roller Bearing Assembly

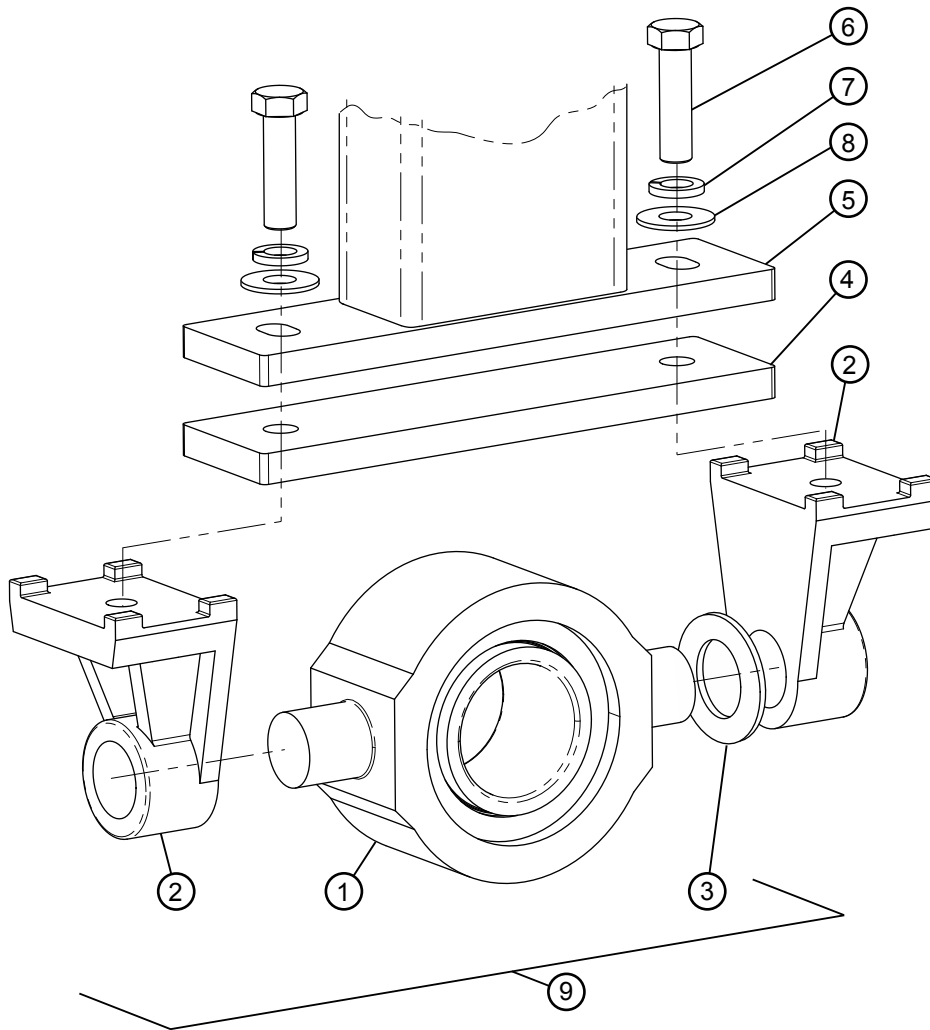

Item	Part Number	Description	Qty. / Roller Arm
1	-----	Trunnion Bearing Assembly	1
2	-----	Trunnion Hanger	2
3	-----	Thrust Washer	2
4	FTB4-00J203	Roller Arm Bearing Shim	1
5	FTB4-00J200	Roller Arm	1
6	212508	M18-2.5 X 70 mm Hex Head Bolt	2
7	LWASHER-12	3/4" Lock Washer	2
8	FWASHER-12	3/4" Flat Washer	2
9	553389	Trunnion Bearing Assembly Includes items 1, 2, and 3	1

**Ring / Roller Assembly**

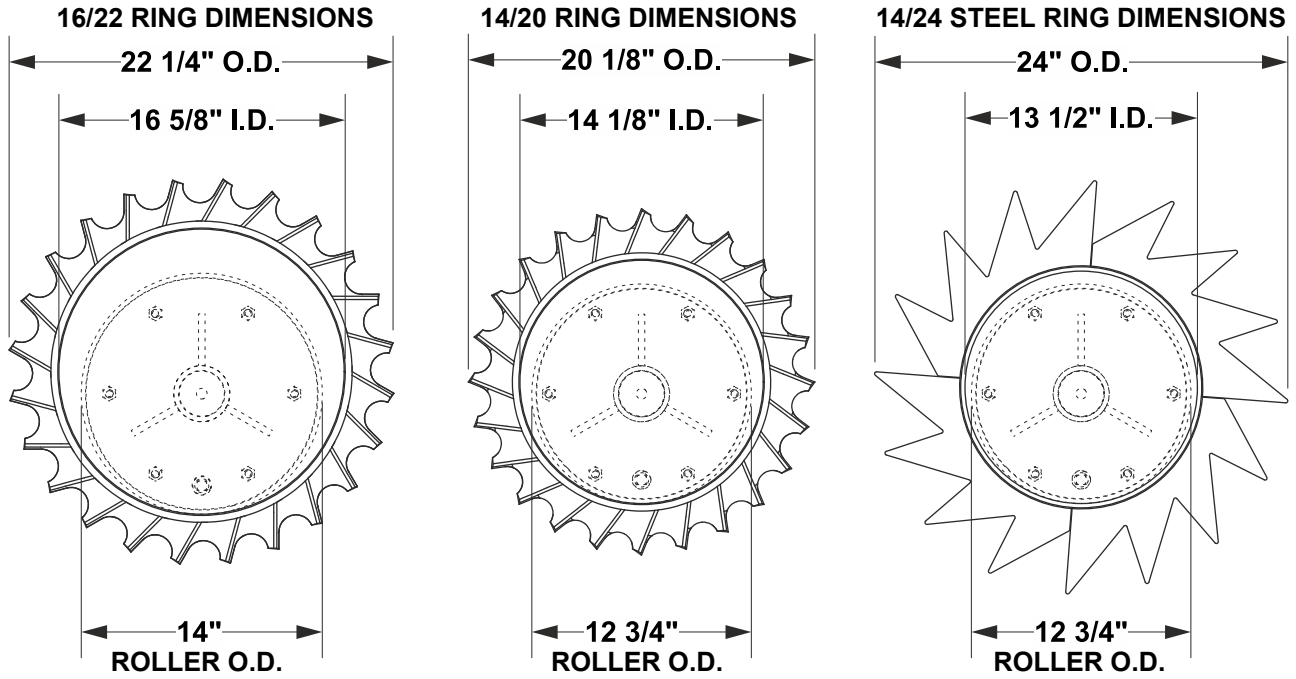

Pipe Size	Ring Size	Ring Part No
12"	14/20	TPP3353D
12"	14/24S	DPR-14X24S
14"	16/22	TPP3354D

**S-Tine Bar and Lift Axle Bar Brackets Orientation**

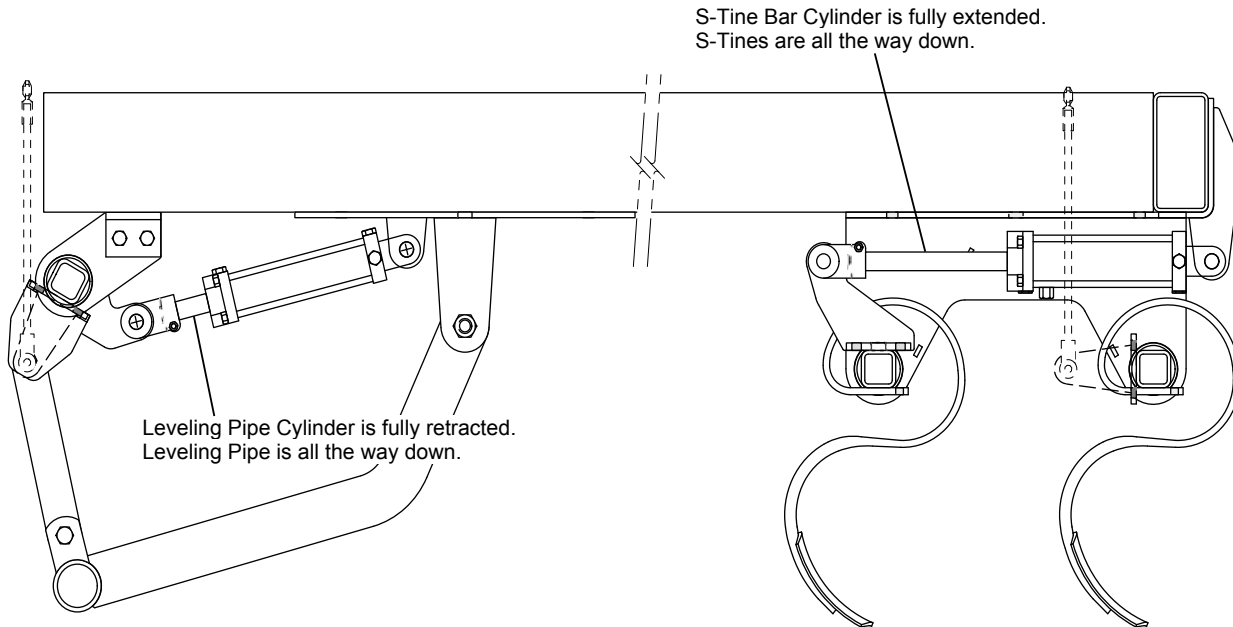

**S-Tine and S-Tine Tie Bar Assembly**

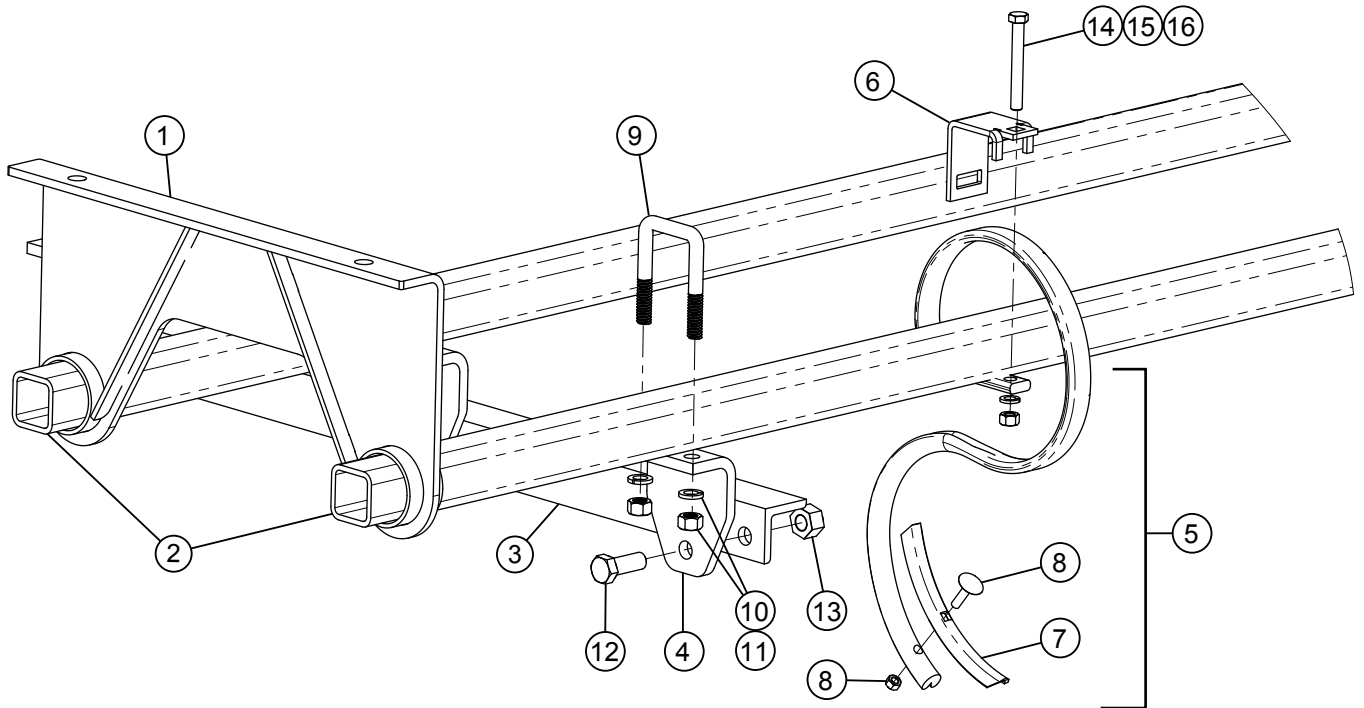

Item	Part Number	Description	Qty.
1	TBU-00K000	S-Tine Bar Hanger	20
2	FTB4-15Q101	S-Tine Bar for 15 Ft. Main Frame	4
	FTB4-75Q102	S-Tine Bar for 7.5 Ft. Wing	8
3	FTB4-00S300	S-Tine Tie Bar for Main Frame	4
	FTB4-00S400	S-Tine Tie Bar for Wings	4
4	TBU-00L300	S-Tine Linkage Plate	24
5	GST-50125S	1/2" X 1-1/4" S-Tine (includes items 7 and 8)	Varies
6	GST-2CL250	2-1/2" S-Tine Bar Clamp	Varies
7	GST-25150P	1/4" S-Tine Point (Replacement only)	Varies
8	GST-0624BN	3/8" X 1-1/2" E-Head Bolt with Nut (Replacement only)	Varies
9	UBNC10X41S	5/8" NC Square U-Bolt	24
10	LWASHER-10	5/8" Lock Washer	48
11	HXNUT-10NC	5/8" NC Hex Nut	48
12	CSNC512032	3/4" X 2" Gr.5 NC Cap Screw	24
13	NYNUT-12NC	3/4" NC Nylon Lock Hex Nut	24
14	CBNC508064	1/2" X 4" Gr.5 NC Carriage Bolt	Varies
15	LWASHER-08	1/2" Lock Washer	Varies
16	HXNUT-08NC	1/2" NC Hex Nut	Varies

**S-Tines Layout (15 Ft. Main Frame)**

**S-Tine Bar Hangers Orientation (Main Frame)**

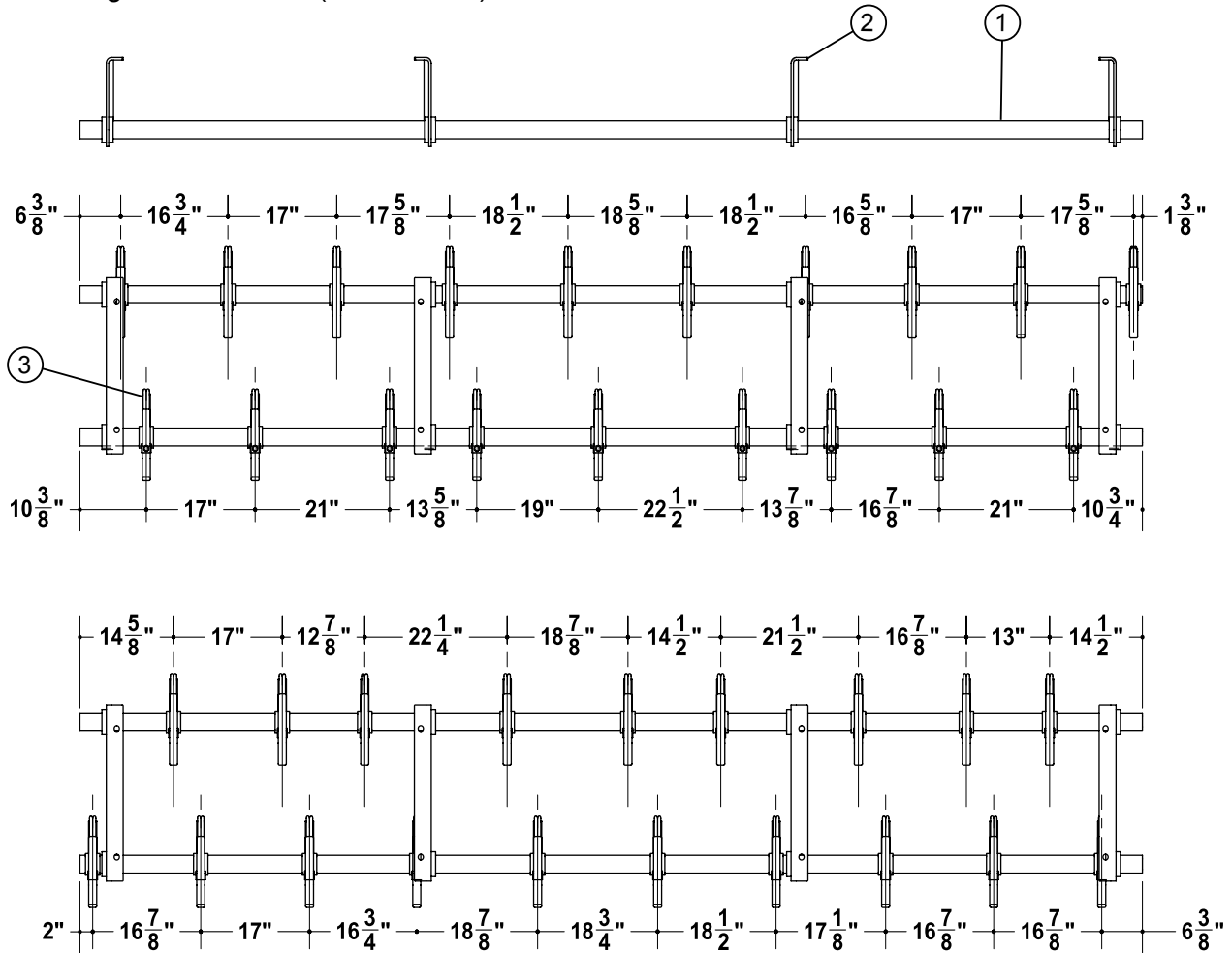

**FRONT OF MACHINE**

Item	Part Number	Description	Qty.
1	FTB4-15Q101	S-Tine Bar for 15 Ft. Main Frame	4
2	TBU-00K000	S-Tine Bar Hanger	20
3	GST-50125S	1/2" X 1-1/4" S-Tine	38
4	FTB4-00S300	S-Tine Tie Bar for Main Frame	4



**S-Tines Layout (7.5 Ft. Wings)**

**S-Tine Bar Hangers Orientation (Wings)**

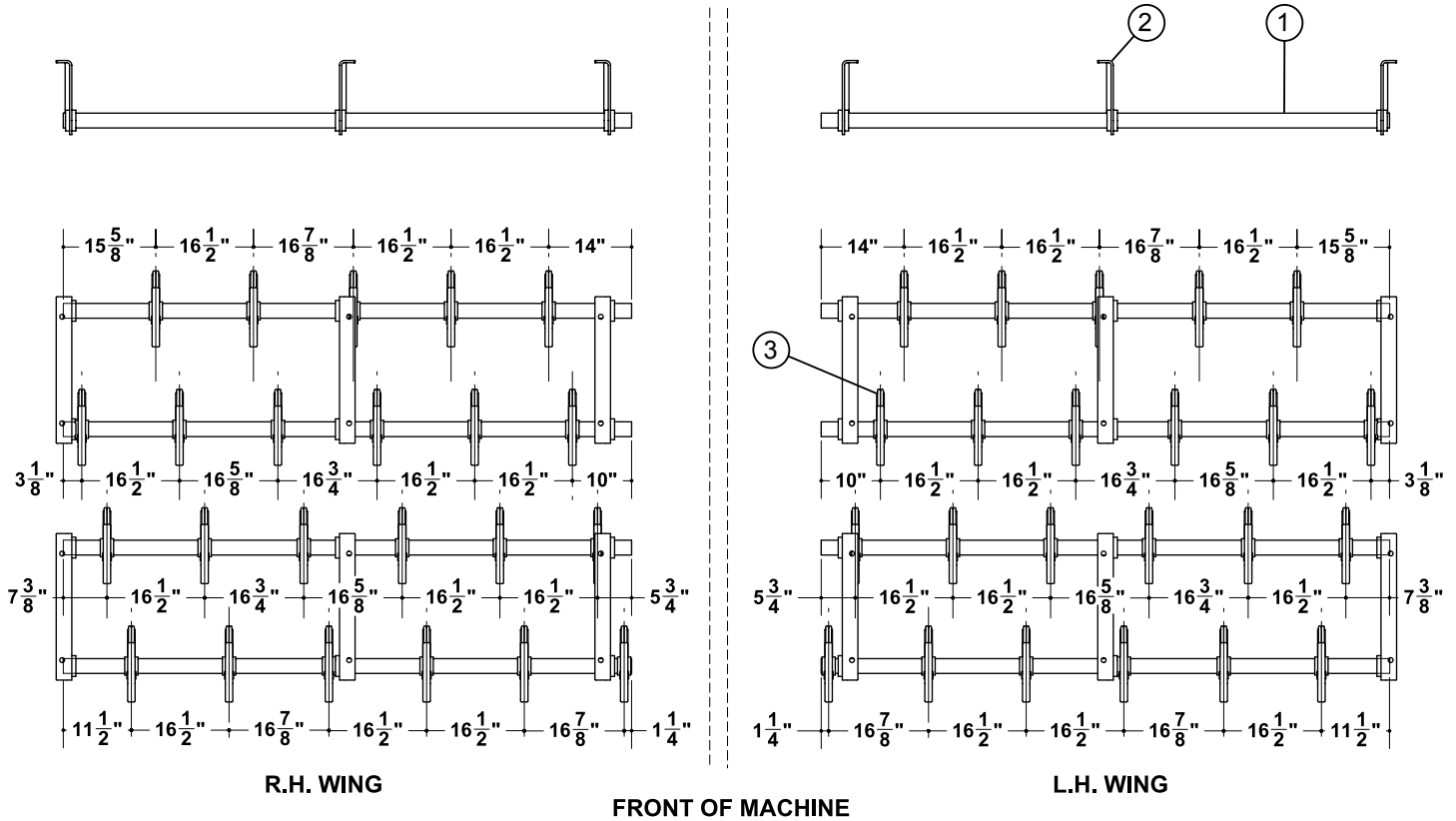

Item	Part Number	Description	Qty.
1	FTB4-75Q102	S-Tine Bar for 7.5 Ft. Wings	8
2	TBU-00K000	S-Tine Bar Hanger	12
3	GST-50125S	1/2" X 1-1/4" S-Tine	46
4	FTB4-00S400	S-Tine Tie Bar for Wings	4

**Front to Rear Level Bar to Wheel Axle Connection**

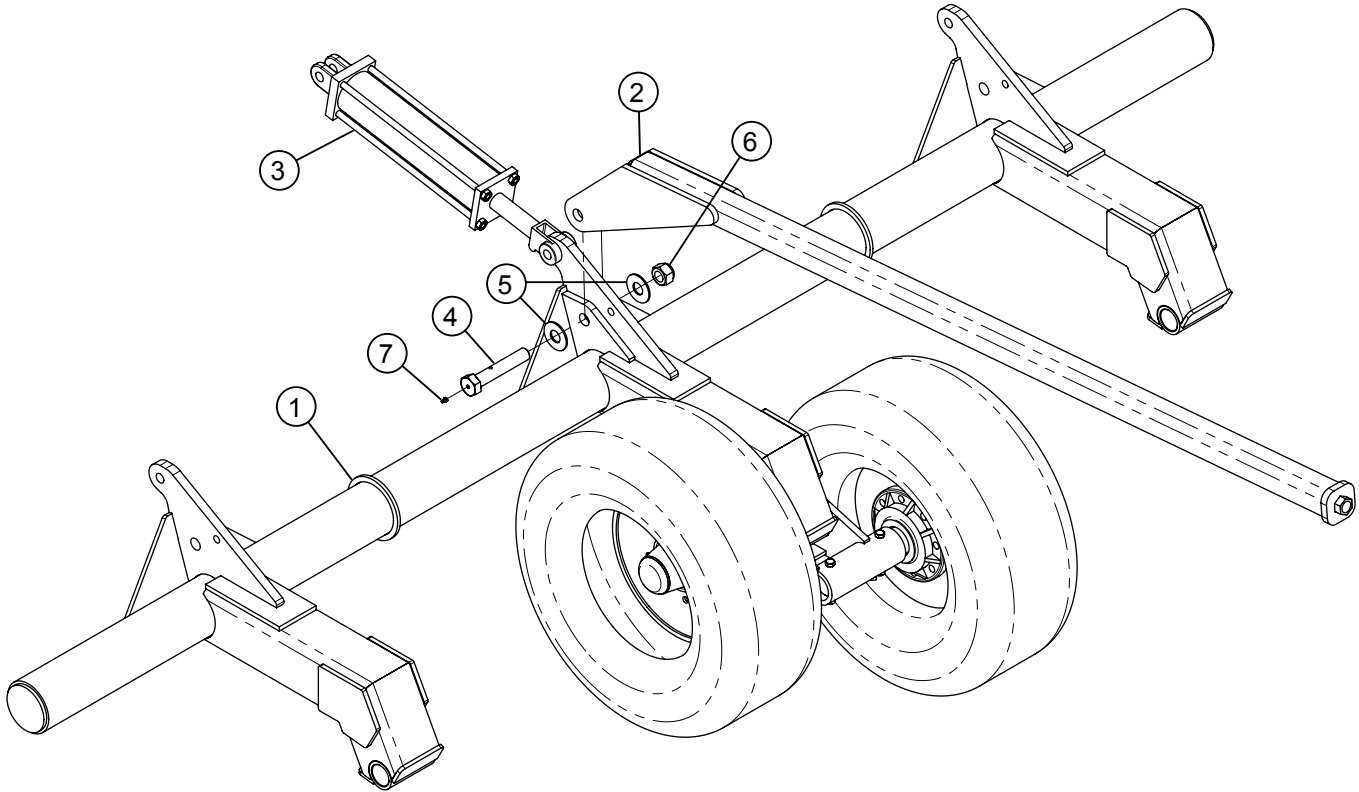

Item	Part Number	Description	Qty.
1	-----	FTB4 Wheel Axle	1
2	FTB4-00B100	Front to Rear Level Bar	1
3	GHC-40160T	4" X 16" Tie Rod Hydraulic Cylinder	3
4	FTB4-00L300	Wheel Axle to Level Bar Bolt with Zerk	1
5	FWASHER-20	1-1/4" Flat Washer	2
6	NYNUT-20NC	1-1/4" NC Nylon Lock Hex Nut	1
7	GMB-ZERKTH	Threaded Grease Zerk	1

**Front to Rear Level System Assembly**

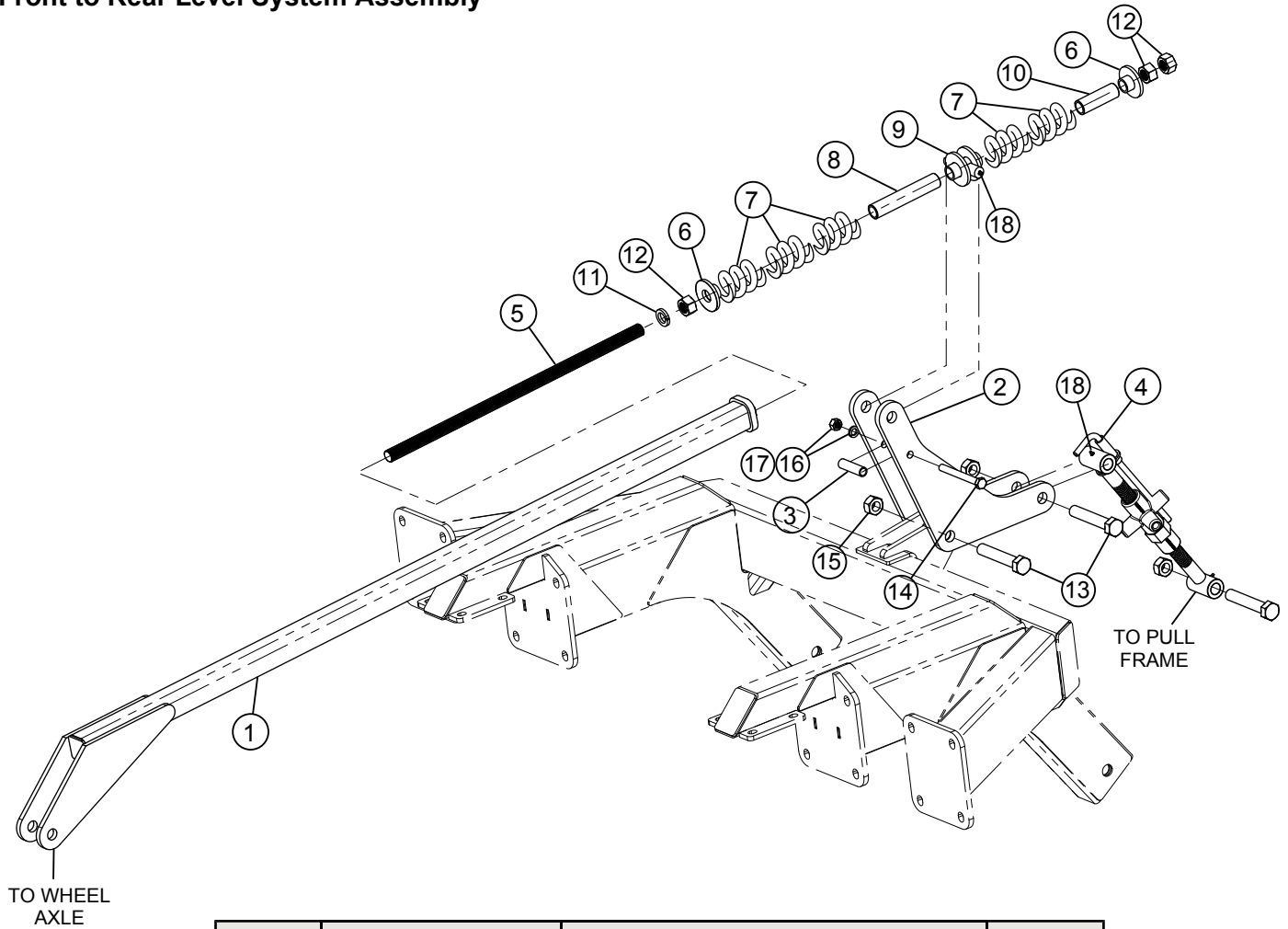

Item	Part Number	Description	Qty.
1	FTB4-00B100	Front to Rear Level Bar	1
2	FTB4-00B200	Front to Rear Level Link	2
3	DTH-00G300	Front to Rear Level Link Spacer	1
4	DTH-00H000	Front Turnbuckle Assembly	1
5	ATNC20X576G8	1-1/4" All Thread Bar Gr.8	1
6	FTP-00S100	Spring System Washer	2
7	GSR-BUSH01	Front to Rear Level Compression Spring	5
8	FTB4-00B400	Spring Bushing 9" Long	1
9	FTB4-00B300	FTB4 Pad Eye Weldment	1
10	FTP-00S004	Spring Bushing 5" Long	1
11	LWASHER-20	1-1/4" Lock Washer	1
12	HXNUT-20NC	1-1/4" NC Hex Nut	3
13	CSNC820112	1-1/4" X 7" Gr.8 NC Cap Screw	3
14	CSNC512104	3/4" X 6-1/2" Gr.5 NC Cap Screw	1
15	NYNUT-20NC	1-1/4" NC Nylon Lock Hex Nut	2
16	FWASHER-12	3/4" Flat Washer	1
17	HXNUT-12NC	3/4" NC Hex Nut	1
18	GMB-ZERKTH	Threaded Grease Zerk	4

### Wheel Axle with Walking Beams Assembly

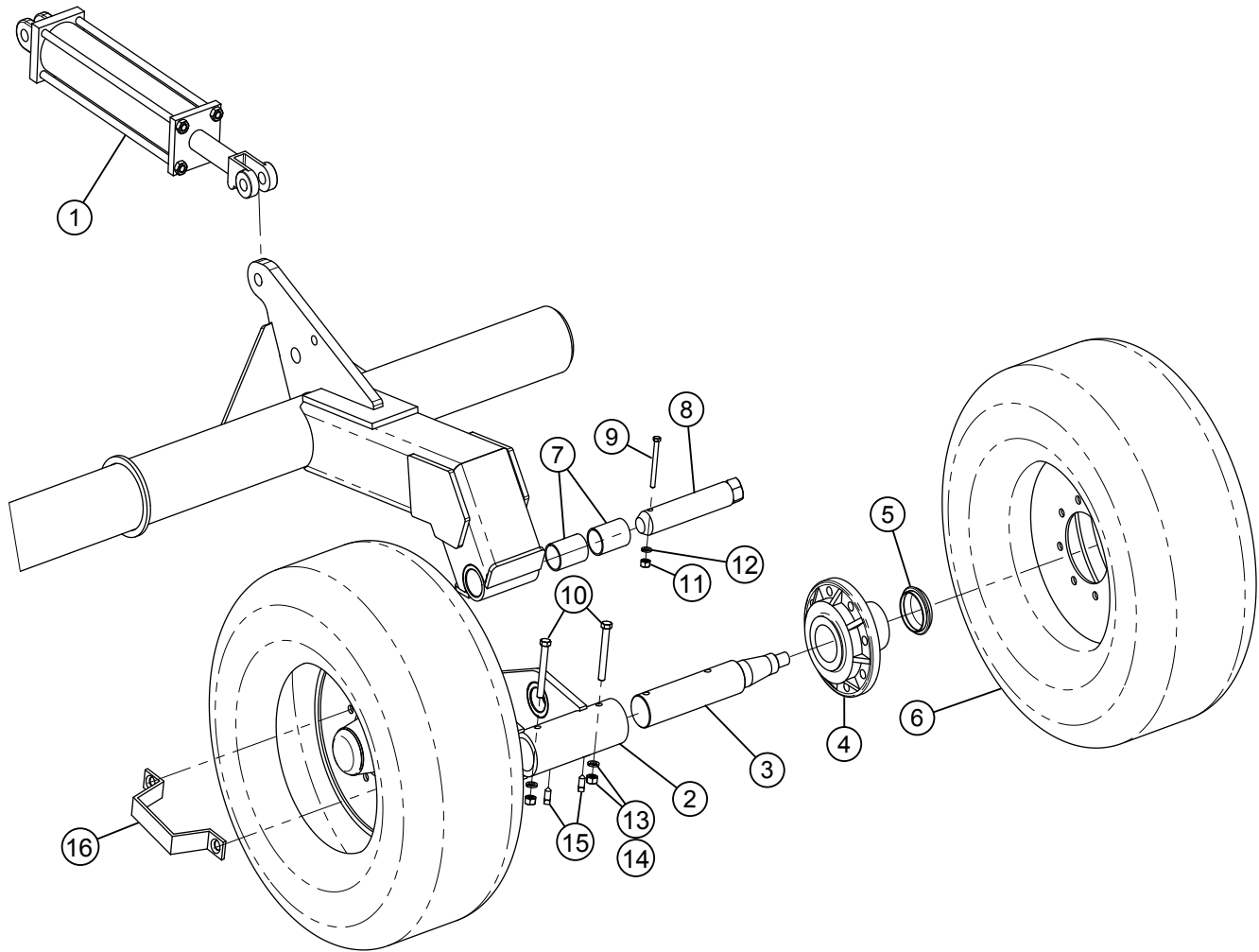

Item	Part Number	Description	Qty.
1	GHC-40160T	4" X 16" Tie Rod Hydraulic Cylinder	3
2	FTB4-00L200	Walking Beam 2018	3
3	FTB4-00M300	2-3/4" Removable Spindle	6
4	GHB-8X8XHZ	8 X 8 XHVY Hub Assembly (see p. for details)	6
5	GHB-8XXCAP	Hub Cap for 8 X 8 Hub	6
6	GWT-121614	12.5 X 16 14 Ply Tire with Wheel Assembly	6
7	GBR-3236G48	2" X 2-1/4" Self-Lubricating Bushings	6
8	FTB4-00M206	Walking Beam Pivot Pin	3
9	CSNC507056	7/16" X 3-1/2" NC Gr.5 Cap Screw	3
10	CSNC509072	9/16" X 4-1/2" NC Gr.5 Cap Screw	12
11	HXNUT-07NC	7/16" NC Hex Nut	3
12	LWASHER-07	7/16" Lock Washer	3
13	HXNUT-09NC	9/16" NC Hex Nut	12
14	LWASHER-09	9/16" Lock Washer	12
15	SSNCS08X16	1/2" X 1" NC Square Head Set Screw	12
16	SSR-00B200	Hub Cap Retainer	6

### Walking Beam Hub Assembly

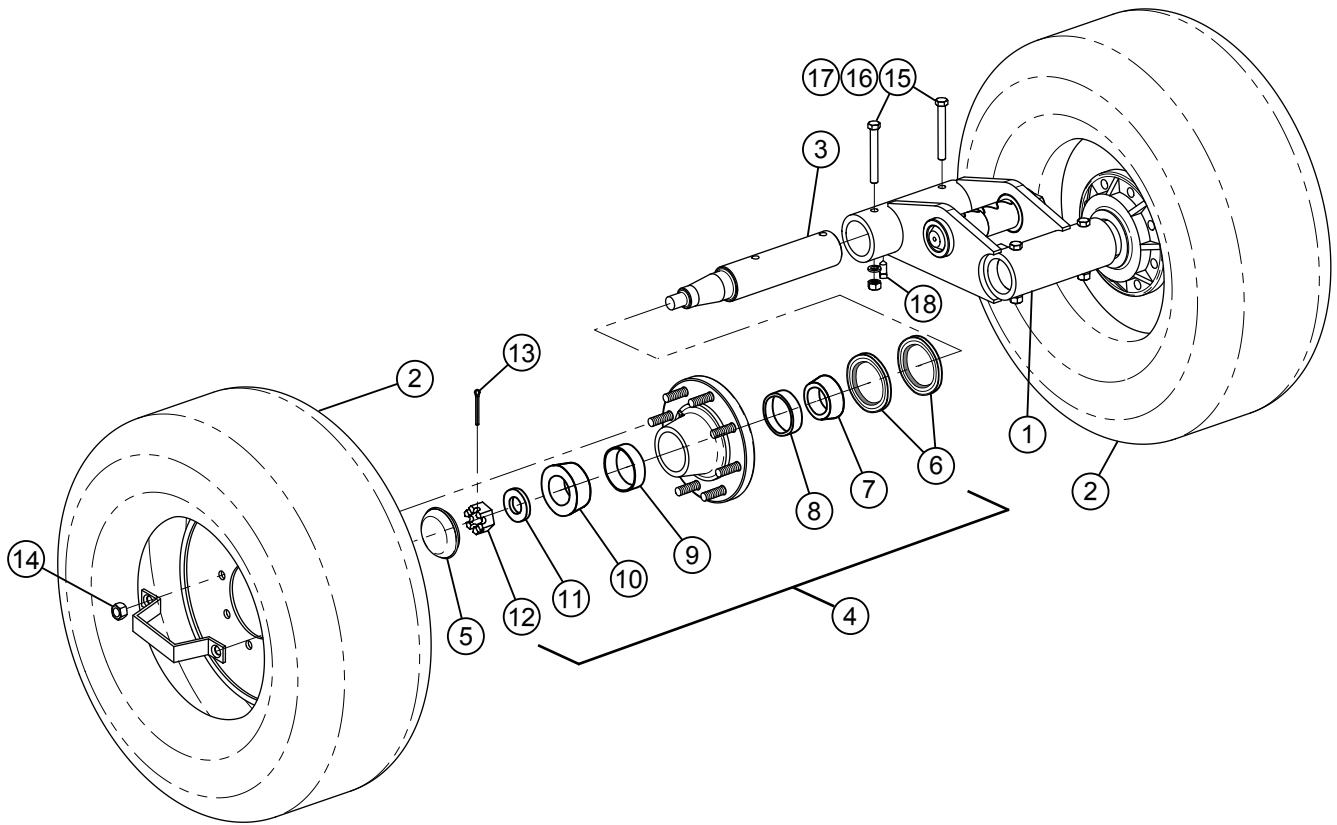

Item	Part Number	Description	Qty.
1	FTB4-00L200	Walking Beam 2018	3
2	GWT-121614	12.5 X 16 14 Ply Tire with Wheel Assembly	3
3	FTB4-00M300	2-3/4" Removable Spindle	6
4	GHB-8X8XHZ	8 X 8 XHVV Hub Assembly (includes items 6-13)	6
5	GHB-8XXCAP	Hub Cap for 8 X 8 Hub	6
6	GHB-8XXGSL	Grease Seal (2 per Hub required)	12
7	GHB-8XXICN	Inner Bearing Cone for 8X8 XHVV Hub	6
8	GHB-8XXIRC	Inner Bearing Cup for 8X8 XHVV Hub	6
9	GHB-8XXORC	Outer Bearing Cup for 8X8 XHVV Hub	6
10	GHB-8XXOCN	Outer Bearing Cone for 8X8 XHVV Hub	6
11	GSP-16SPWA	1" Dia. Spindle Flat Washer	6
12	GSP-16CANT	1" Dial Spindle Castle Nut	6
13	GPN-03X32C	3/16" X 2" Cotter Pin	6
14	WHN-10NFWN	Hub Lug Nuts 5/8" NF for 8 X 8 XHVV Hub	48
15	CSNC509072	9/16" X 4-1/2" NC Gr.5 Cap Screw	12
16	HXNUT-09NC	9/16" NC Hex Nut	12
17	LWASHER-09	9/16" Lock Washer	12
18	SSNCS08X16	1/2" X 1" NC Square Head Set Screw	12

### Wheel Axle Bearing Assembly

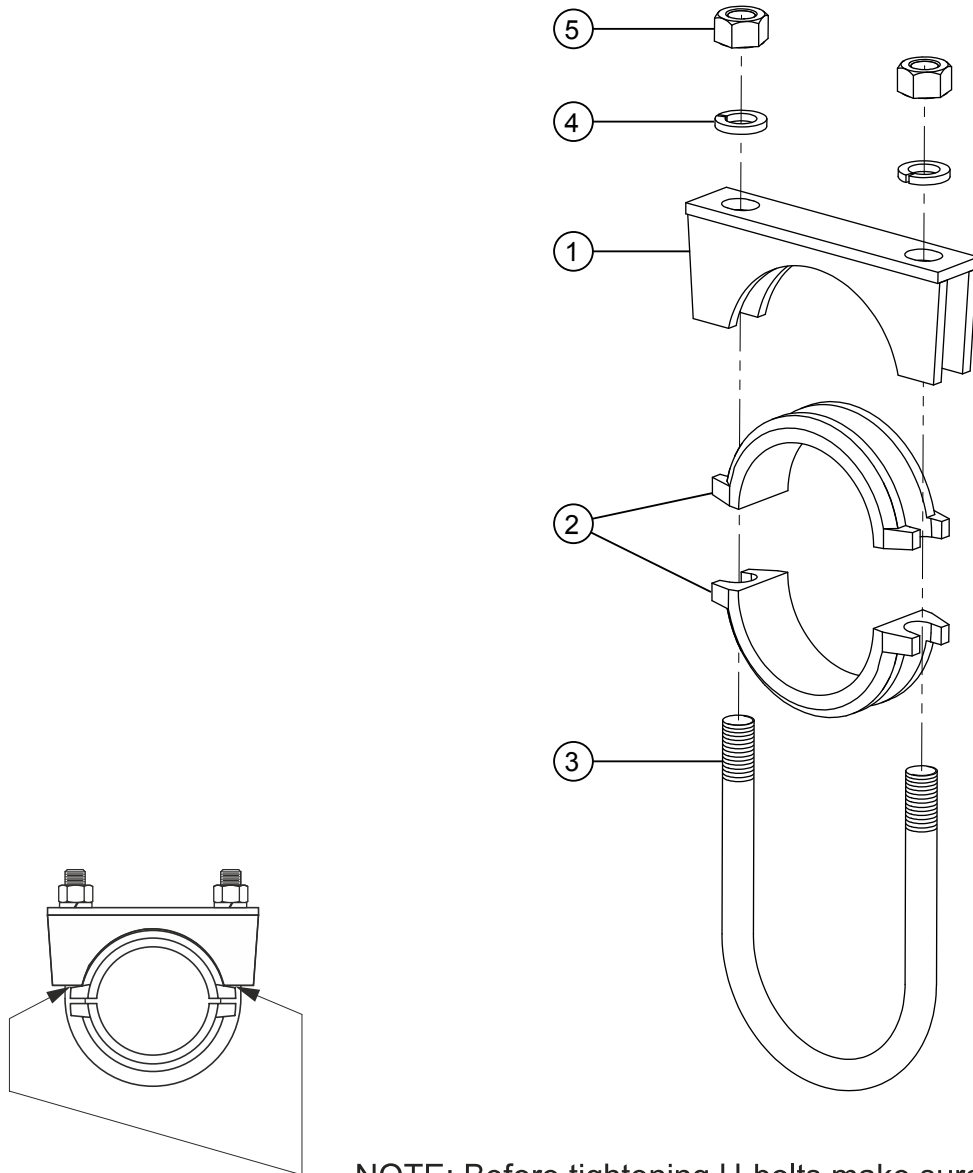

NOTE: Before tightening U-bolts make sure you have equal amount of space on each side.

Item	Part Number	Description	Qty.
1	-----	FTB4 Wheel Axle	1
2	FTB4-00B100	Front to Rear Level Bar	1
3	GHC-40160T	4" X 16" Tie Rod Hydraulic Cylinder	3
4	FTB4-00L300	Wheel Axle to Level Bar Bolt with Zerk	1
5	FWASHER-20	1-1/4" Flat Washer	2
	NYNUT-20NC	1-1/4" NC Nylon Lock Hex Nut	1

**Wing Linkage Assembly**

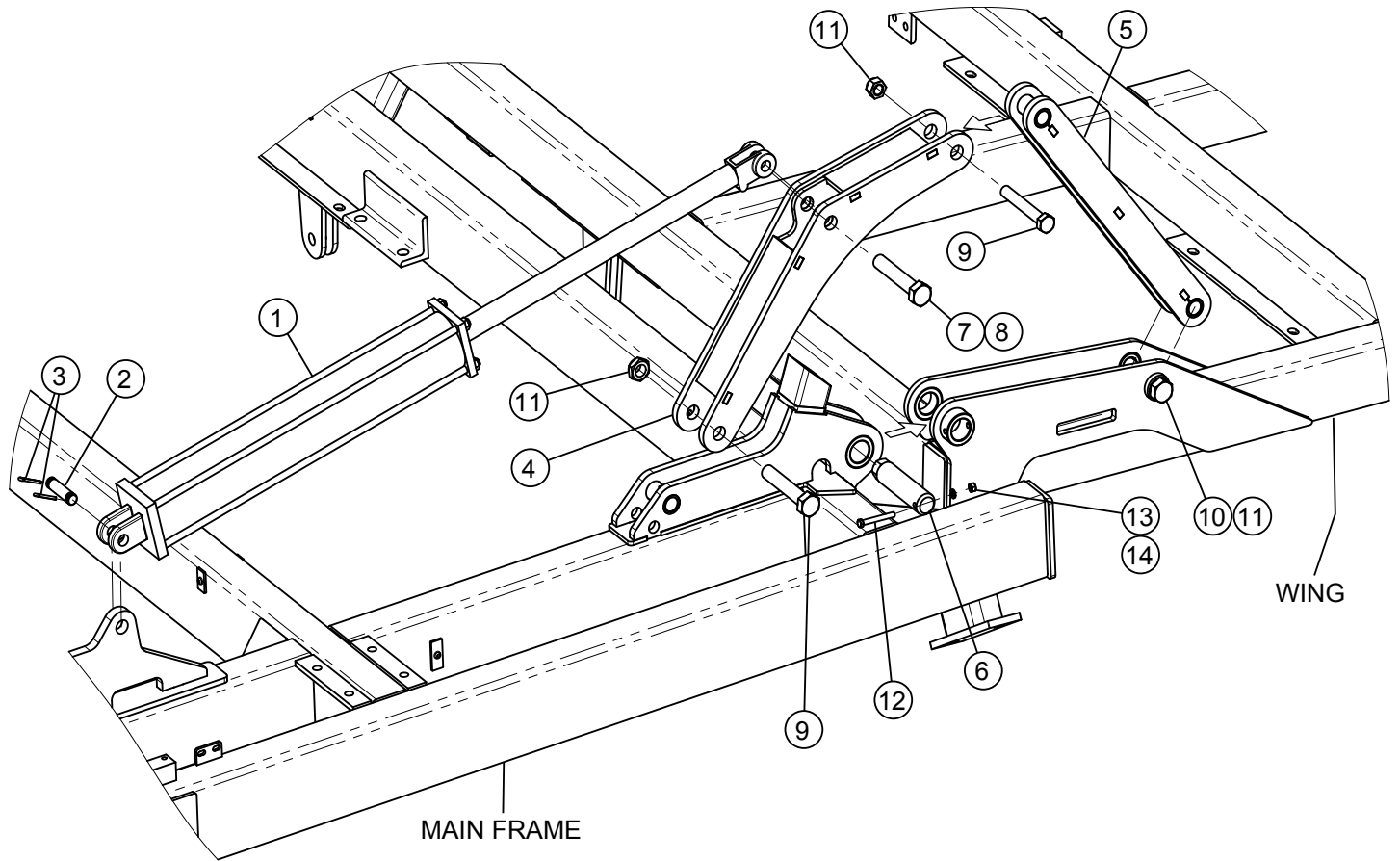

Item	Part Number	Description	Qty.
1	GHC-50300T	Wing Hydraulic Cylinder 5" x 30" Tie Rod	4
2	GPN-1664HC	1" Cylinder Pin	4
3	GPN-05X40C	Cotter Pin	8
4	FTB4-00H100	Wing Linkage L-Link	4
5	FTB4-00H200	Wing Linkage Straight Link	4
6	FTB4-00F700	Wing Hinge Pin 2018	4
7	CSNC820128	1-1/4" X 8" Gr.8 NC Cap Screw	4
8	NYNUT-20NC	1-1/4" NC Nylon Lock Hex Nut	4
9	CSNC820112	1-1/4" X 7" Gr.8 NC Cap Screw	8
10	CSNC520128	1-1/4" X 8" Gr.5 NC Cap Screw	4
11	NYNUT-20NCJ	1-1/4" NC Nylon Lock Hex Jam Nut	12
12	CSNC507056	7/16" X 3-1/2" Gr.5 NC Cap Screw	4
13	LWASHER-07	7/16" Lock Washer	4
14	HXNUT-07NC	7/16" NC Hex Nut	4



**Wheel Axle Cylinder Lockout System Assembly**

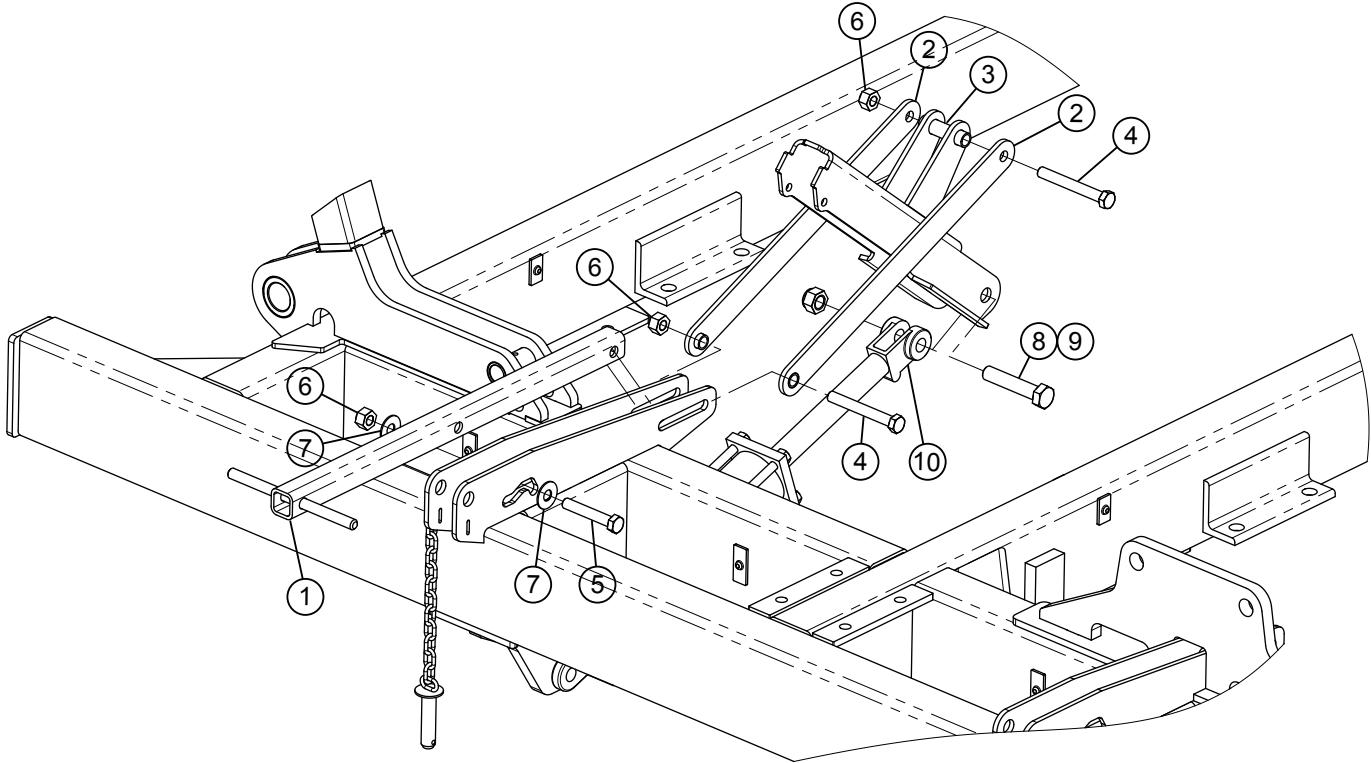

Item	Part Number	Description	Qty.
1	FTB4-00E100	Lockout Extension Tube Handle	3
2	FTB4-00E200	Lockout Link	6
3	FTB4-00E300	Lockout Bar	3
4	CSNC512096	3/4" X 6" Gr.5 NC Cap Screw	6
5	CSNC512072	3/4" X 4-1/2" Gr.5 NC Cap Screw	3
6	NYNUT-12NC	3/4" NC Nylon Lock Hex Nut	9
7	FWASHER-12	3/4" Lock Washer	12
8	CSNC816080	1" X 5" Gr.8 NC Cap Screw	3
9	NYNUT-16NC	1" NC Nylon Lock Hex Nut	3
10	GHC-416LB1	4" X 16" Tie Rod Hydraulic Cylinder	3

**Rear Leveling Pipe Assembly**

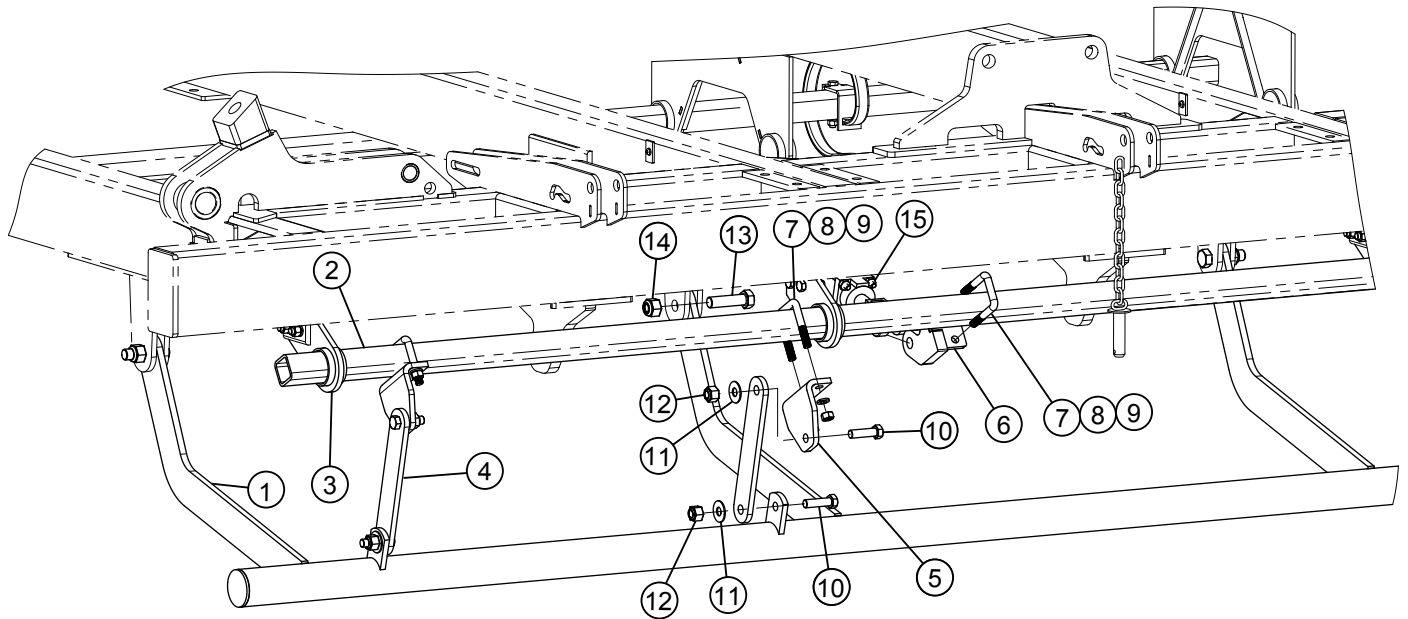

Item	Part Number	Description	Qty.
1	FTB4-15N100	Leveling Pipe for 15 Ft. Main Frame	1
	FTB4-75N200	Leveling Pipe for 7.5 Ft. Wings (pair)	1
2	FTB4-15Q101	Lift Axle Bar for 15 Ft. Main Frame	1
	FTB4-75Q102	Lift Axle Bar for 7.5 Ft. Wings	2
3	TBU-00L100	Lift Axle Bracket 2018	10
4	TBU-00L500	Lift Axle Leveling Bar Link	8
5	TBU-00L300	Lift Axle Linkage Plate	8
6	TBU-00L400	Lift Axle Hydraulic Cylinder Anchor	3
7	UBNC10X41S	5/8" NC Square U-Bolt	Varies
8	HXNUT-10NC	5/8" NC Hex Nut	Varies
9	LWASHER-10	5/8" Lock Washer	Varies
10	CSNC512040	3/4" X 2-1/2" Gr.5 NC Cap Screw	16
11	FWASHER-12	3/4" Flat Washer	16
12	NYNUT-12NC	3/4" NC Nylon Lock Hex Nut	16
13	CSNC516056	1" X 3-1/2" Gr.5 NC Cap Screw	8
14	NYNUT-16NC	1" NC Nylon Lock Hex Nut	8
15	GHC-2508MS	2-1/2" X 8" Series Hydraulic Cylinder	1
	GHC-2758MS	2-3/4" X 8" Series Hydraulic Cylinder	1
	GHC-3008MS	3" X 8" Series Hydraulic Cylinder	1

**Rear Leveling Pipe Depth Indicator Assembly**

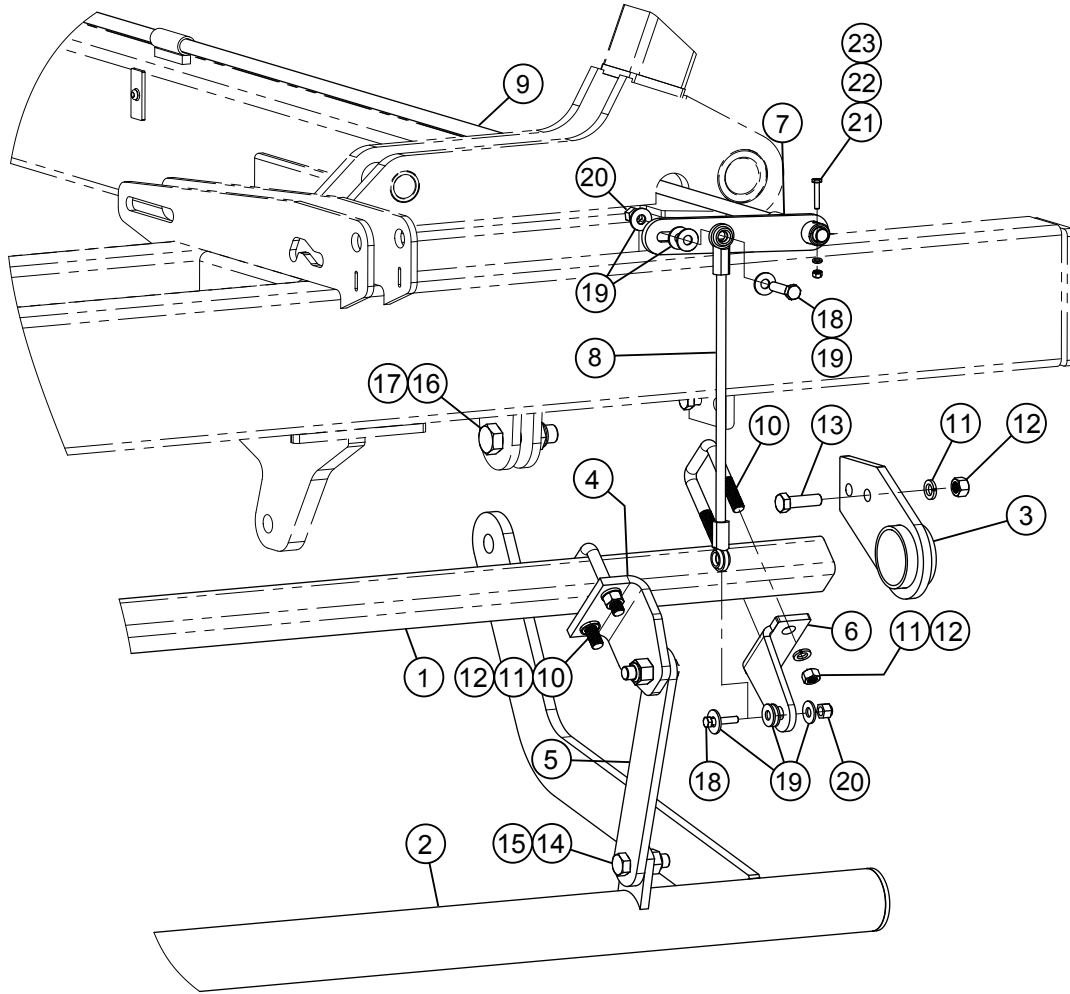

**NOTE: Lift Axle Linkage Plate (item 4) and Depth Indicator Link Mount Bracket (item 6) are facing the same way. See drawing on p. 30 for all brackets orientations.**

Item	Part #	Description	Q'ty
1	FTB4-15Q101	Lift Axle Bar for 15 Ft. Main Frame	1
	FTB4-75Q102	Lift Axle Bar for 7.5 Ft. Wing	2
2	FTB4-15N100	Leveling Pipe for 15 Ft. Main Frame	1
	FTB4-75N200	Leveling Pipe for 7.5 Ft. Wing	2
3	TBU-00L100	TB Lift Axle Bracket 2018	10
4	TBU-00L300	TB Lift Axle Linkage Plate	8
5	TBU-00L500	TB Lift Axle Leveling Bar Link	8
6	FTB4-00V400	Depth Indicator Link Mount.Bracket	2
7	FTB4-00V100	Depth Indicator Swing Arm 2018	2
8	FTB4-00V300	Leveling Pipe Depth Ind. Link	1
9	FTB4-00V600	Leveling Pipe Depth Ind. Rod	1
10	UBNC10X41S	5/8" NC Square U-Bolt	10

Item	Part #	Description	Q'ty
11	LWASHER-10	5/8" Lock Washer	40
12	HXNUT-10NC	5/8" NC Hex Nut	40
13	CSNC510032	5/8" X 2" Gr.5 NC Cap Screw	20
14	CSNC512040	3/4" X 2-1/2" Gr.5 NC Cap Screw	16
15	NYNUT-12NC	3/4" NC Nylon Lock Hex Nut	16
16	CSNC516056	1" X 3.5" Gr.5 NC Cap Screw	8
17	NYNUT-16NC	1" NC Nylon Lock Hex Nut	8
18	CSNC508036	1/2" X 2-1/4" Gr.5 NC Cap Screw	4
19	FWASHER-08	1/2" Flat Washer	16
20	NYNUT-08NC	1/2" NC Nylon Lock Hex Nut	4
21	CSNC504024	1/4" X 1-1/2" Gr.5 NC Cap Screw	2
22	FWASHER-04	1/4" Lock Washer	2
23	HXNUT-04NC	1/4" NC Hex Nut	2

**S-Tine Depth Indicator Assembly**

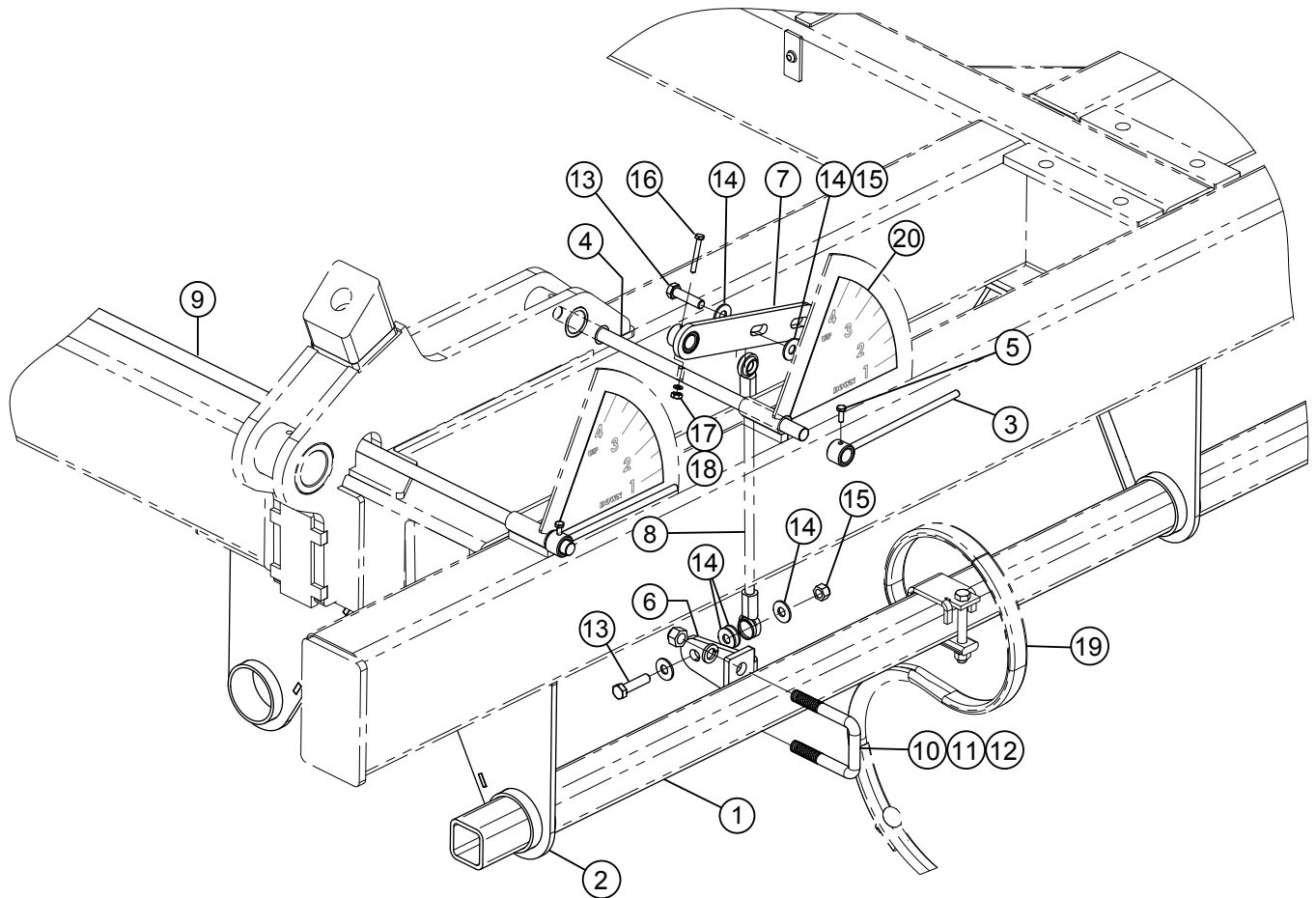

**NOTE: Depth Indicator Link Mount Bracket (item 6) is facing backwards when S-Tines are all the way down. See drawing on p. 30 for all brackets orientation.**

Item	Part #	Description	Q'ty
1	FTB4-15Q101	S-Tine Bar for 15 Ft. Main Frame	1
	FTB4-75Q102	S-Tine Bar for 7.5 Ft. Wing	2
2	TBU-00K000	S-Tine Bar Hanger	20
3	TBU-00R400	TB Depth Indicator Pointer	2
4	FTB4-00V500	S-Tine Depth Indicator Rod	1
5	CSNC505012	5/16" X 3/4" Gr.5 NC Cap Screw	2
6	FTB4-00V400	Depth Indicator Link Mount.Bracket	2
7	FTB4-00V100	Depth Indicator Swing Arm 2018	2
8	FTB4-00V200	S-Tine Depth Indicator Link	1
9	FTB4-00V600	Leveling Pipe Depth Ind. Rod	1
10	UBNC10X41S	5/8" NC Square U-Bolt	10

Item	Part #	Description	Q'ty
11	LWASHER-10	5/8" Lock Washer	40
12	HXNUT-10NC	5/8" NC Hex Nut	40
13	CSNC508036	1/2" X 2-1/4" Gr.5 NC Cap Screw	4
14	FWASHER-08	1/2" Flat Washer	16
15	NYNUT-08NC	1/2" NC Nylon Lock Hex Nut	4
16	CSNC504024	1/4" X 1-1/2" Gr.5 NC Cap Screw	
17	FWASHER-04	1/4" Lock Washer	2
18	HXNUT-04NC	1/4" NC Hex Nut	2
19	GST-50125S	1/2" X 1-1/4" S-Tine with Point	Varies
20	D128TBDEPTH	Depth Indicator Decal	2

**Front Main Frame Steel Ring Roller Scraper Assembly (Optional)**

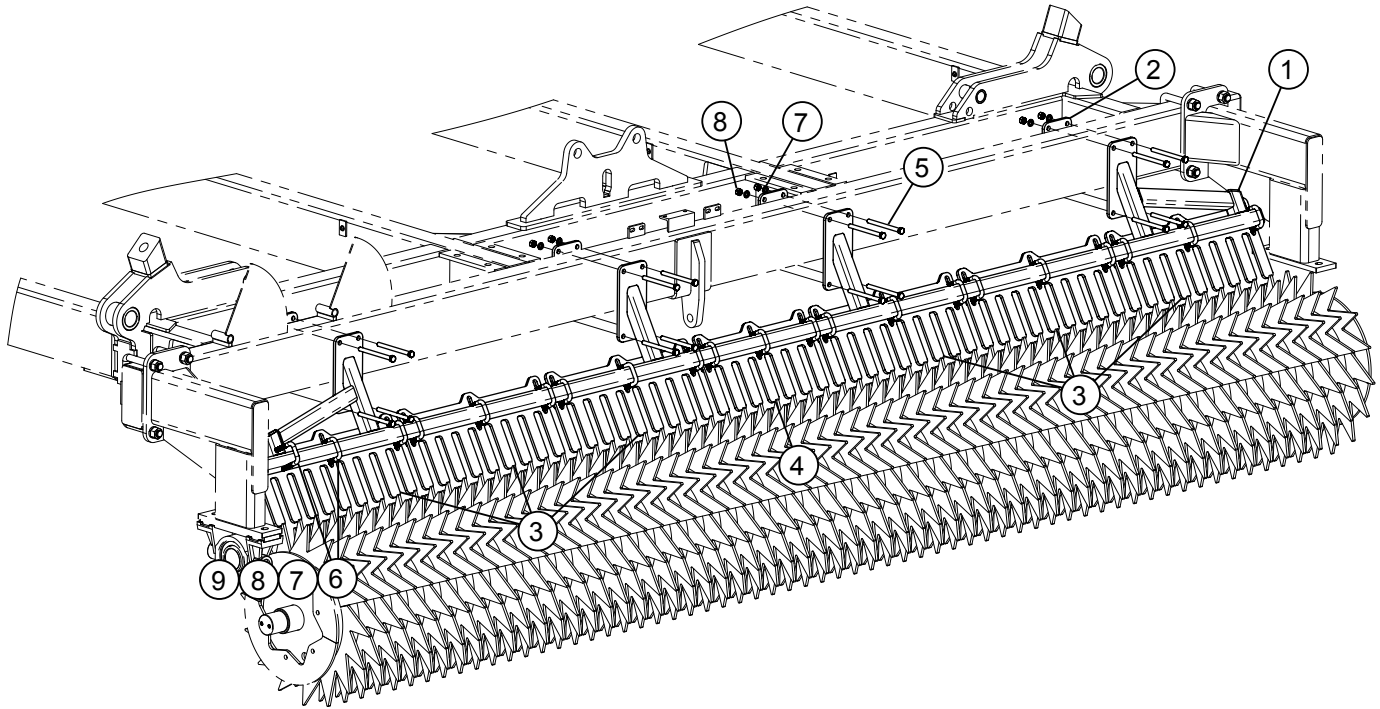

Item	Part Number	Description	Qty.
1	FTB4-13W100	Front Main Frame Roller Scraper Frame 13 Ft.	1
	FTB4-15W100	Front Main Frame Roller Scraper Frame 15 Ft.	1
2	FTB4-00W102	Main Frame Scraper Frame Mounting Plate	4
3	SWKS-0077	Roller Scraper 9-Paddle	6
4	SWKS-0075	Roller Scraper 7-Paddle	1
5	CSNC508096	1/2" X 6" Gr.5 NC Cap Screw	16
6	UBNC08X33S	1/2" Square U-Bolt for 2" X 2" Tube	21
7	LWASHER-08	1/2" Lock Washer	58
8	HXNUT-08NC	1/2" NC Hex Nut	58
9	FWASHER-08	1/2" Flat Washer	42

**Front Wing Steel Ring Roller Scraper Assembly (Optional)**

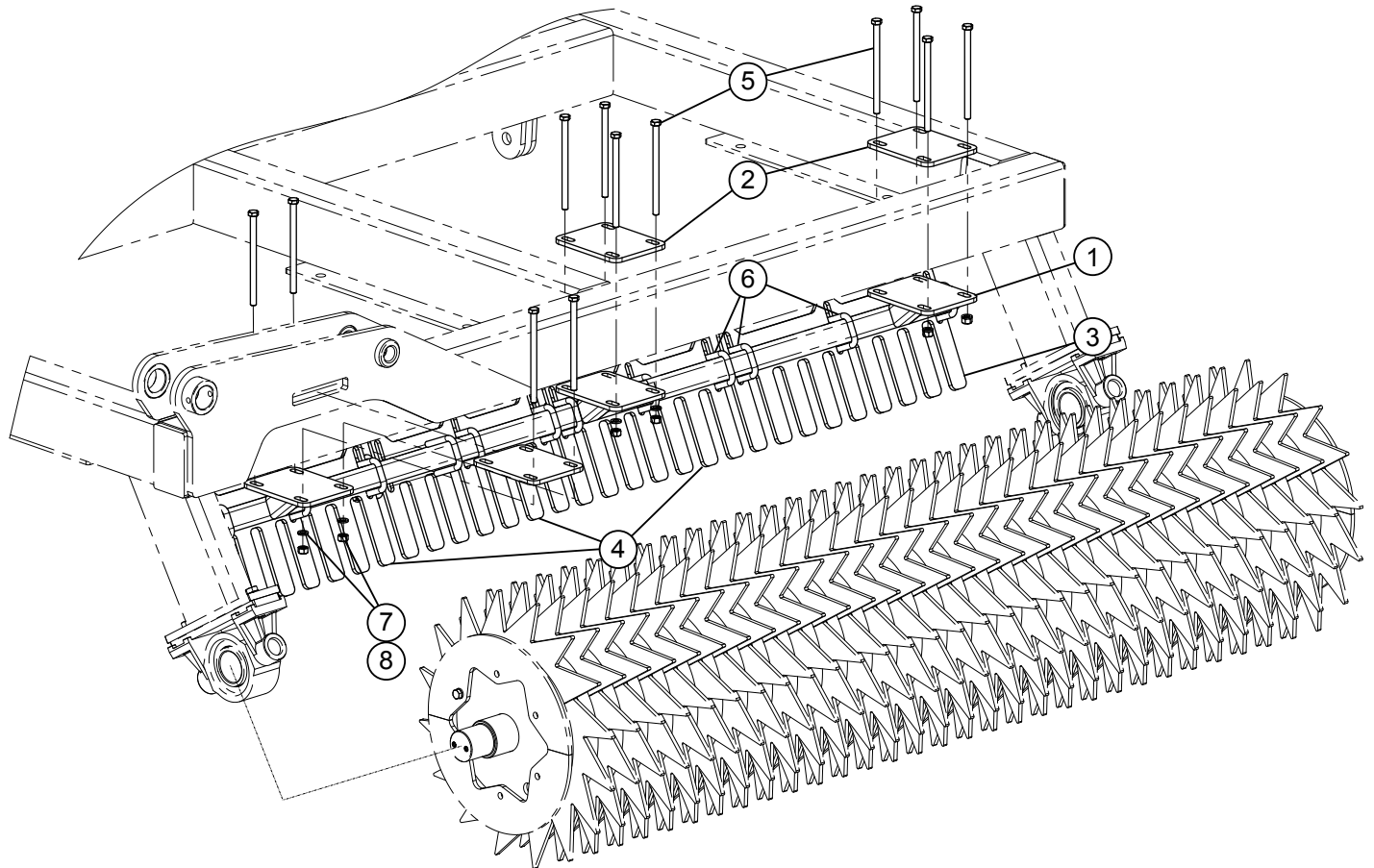

Item	Part Number	Description	Qty. / Pair
1	FTB4-75W200	Front Wing Roller Scraper Frame 7.5 Ft.	2
	FTB4-65W200	Front Wing Roller Scraper Frame 6.5 Ft.	2
2	FTB4-00W202	Wing Scraper Frame Mounting Plate	6
3	SWKS-0077	Roller Scraper 9-Paddle	2
4	SWKS-0075	Roller Scraper 7-Paddle	6
5	CSNC508128	1/2" X 8" Gr.5 NC Cap Screw	24
6	UBNC08X33S	1/2" Square U-Bolt for 2" X 2" Tube	24
7	LWASHER-08	1/2" Lock Washer	72
8	HXNUT-08NC	1/2" NC Hex Nut	72
9	FWASHER-08	1/2" Flat Washer	48

**Rear Trail Hitch Assembly (Optional)**

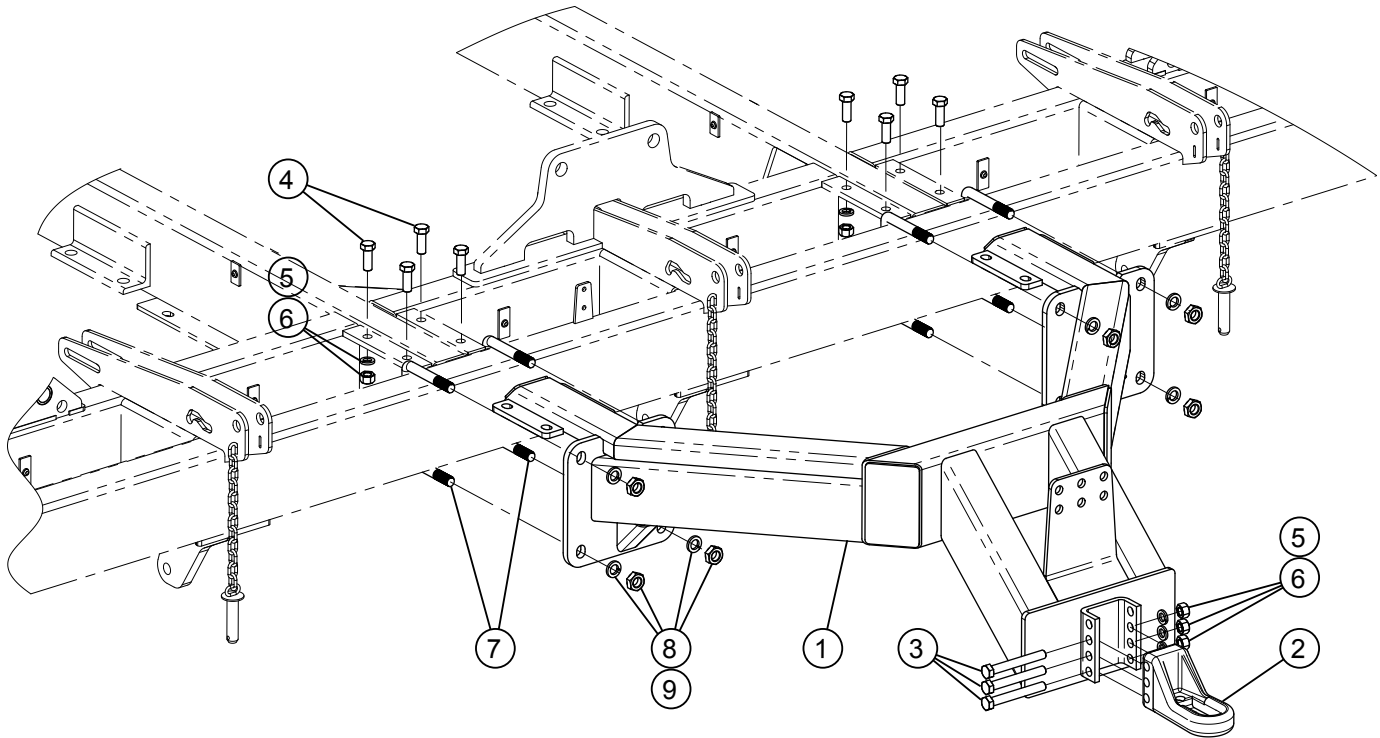

Item	Part Number	Description	Qty.
1	FTB4-00T000	Rear Trail Hitch (Optional)	1
2	GMB-HITCHCA3	Perfect Hitch CA3	1
3	CSNC512096	3/4" X 6" Gr.5 NC Cap Screw	3
4	CSNC512032	3/4" X 2" Gr.5 NC Cap Screw	8
5	LWASHER-12	3/4" Lock Washer	11
6	HXNUT-12NC	3/4" NC Hex Nut	11
7	UBNF14128S	7/8" NF Square U-Bolt	4
8	LWASHER-14	7/8" Lock Washer	8
9	HXNUT-14NF	7/8" NF Hex Nut	8

***NOTE: HKFTB4-TH - Hydraulic Hose Kit for Trail Hitch is available to connect hydraulically operated implements to this trail hitch. It includes two lead hoses and all fittings (see p. 51).***



**HYDRAULIC DIAGRAMS**

**Wings Hydraulic Circuit**

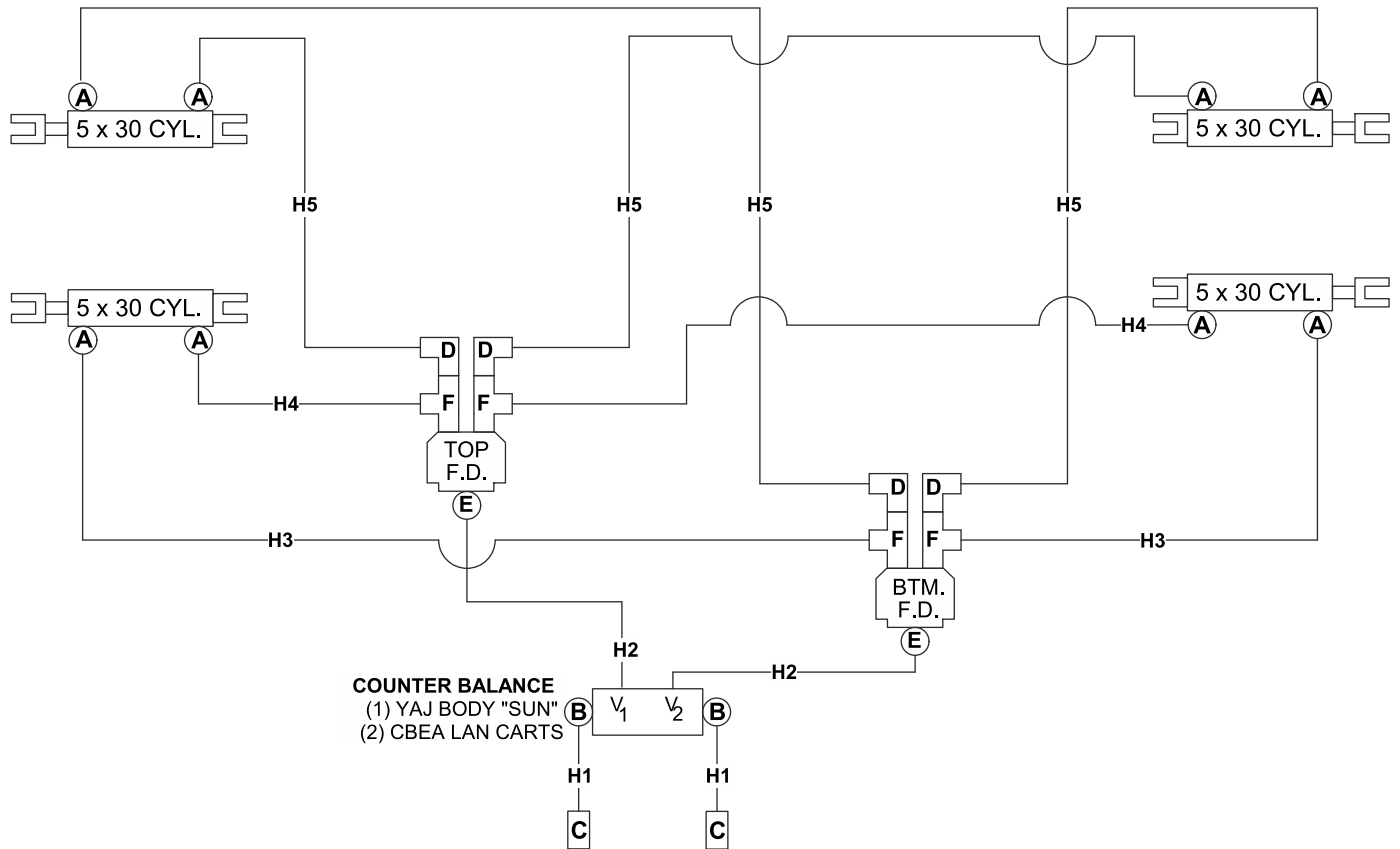

Hose / Hyd. Line / Fitting Number	Description	Qty.
H1	Hose 8MP-8FJX 216" Long - Lead Hose	2
H2	Hose 8MB-8FJX 14" Long	2
H3	Hose 8FJX-8FJX 48" Long	2
H4	Hose 8FJX-8FJX 30" Long	2
H5	Hose 8FJX-8FJX 144" Long	4
A	FMBMJ90108 10MB - 8MJ 90 Elbow	8
B	FMBMJ9088 8MB-8MJ 90 Elbow	2
C	FFP08000PT 8FP Pioneer Tips	2
D	FMJFJX9088 8FJX-8MJ 90 Elbow	4
E	FMBMJ88C 8MB-8MJ Straight Cpling	2
F	FMJMBMJT08 8MB-8MJ-8MJ Tee	4

Wheel Axle Hydraulic Circuit

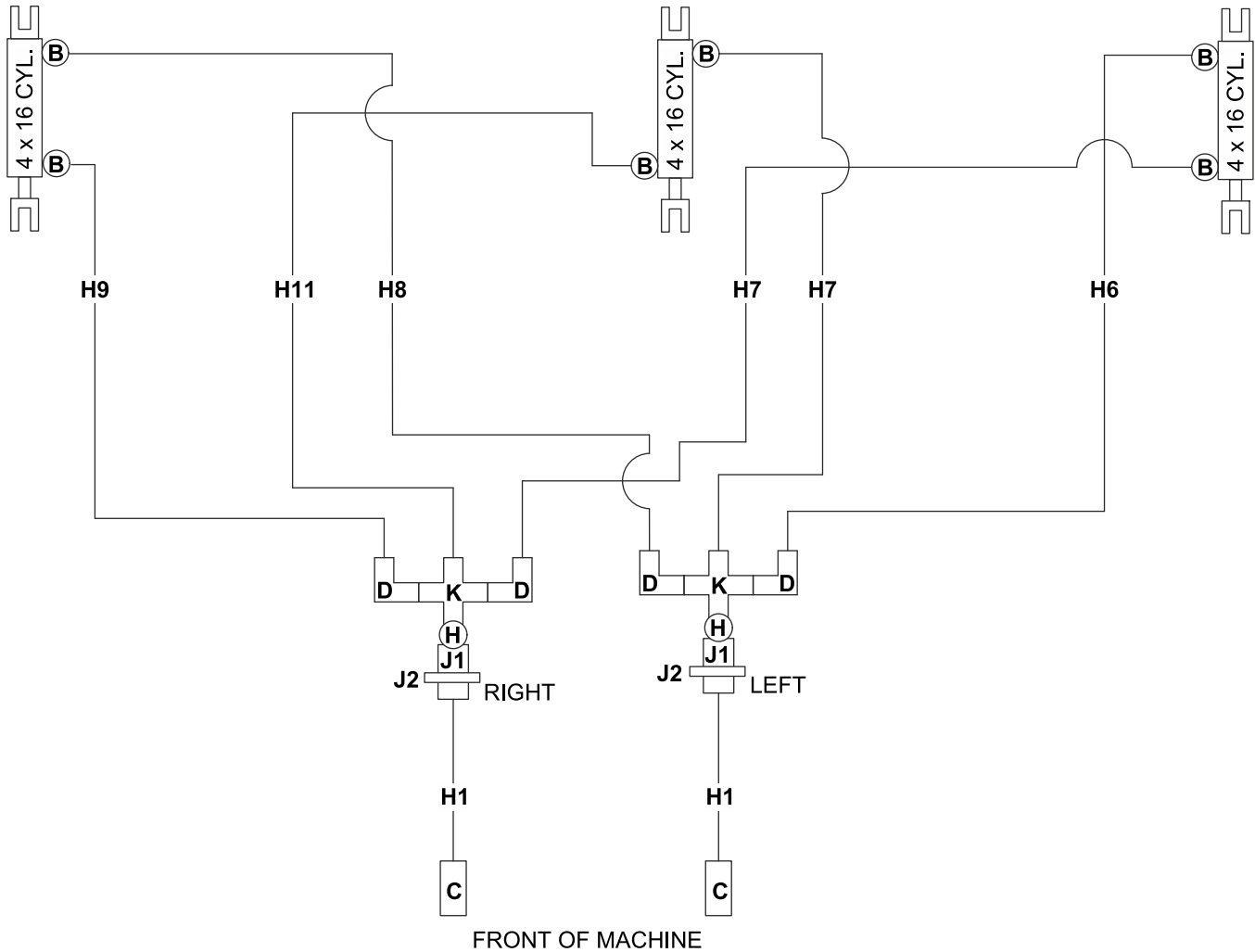

Hose / Hyd. Line / Fitting Number	Description	Qty.
H1	Hose 8MP-8FJX 216" Long - Lead Hose	2
H6	Hose 8FJX-8FJX 230" Long	1
H7	Hose 8FJX-8FJX 168" Long	2
H8	Hose 8FJX-8FJX 180" Long	1
H9	Hose 8FJX-8FJX 215" Long	1
H11	Hose 8FJX-8FJX 155" Long	1
B	FMBMJ9088 8MB-8MJ 90 Elbow	6
C	FFP08000PT 8FP Pioneer Tips	2
D	FMJFJX9088 8FJX-8MJ 90 Elbow	4
H	FFJXFJX88C 8FJX-8FJX Straight Coupling	2
J1	FMJMjH88 8MJ-8MJ Straight Bulkhead	2
J2	FHN88HN 8HN Bulkhead Nut	2
K	FMJR8 8MJ Cross Fitting	2

**S-Tines Hydraulic Circuit**

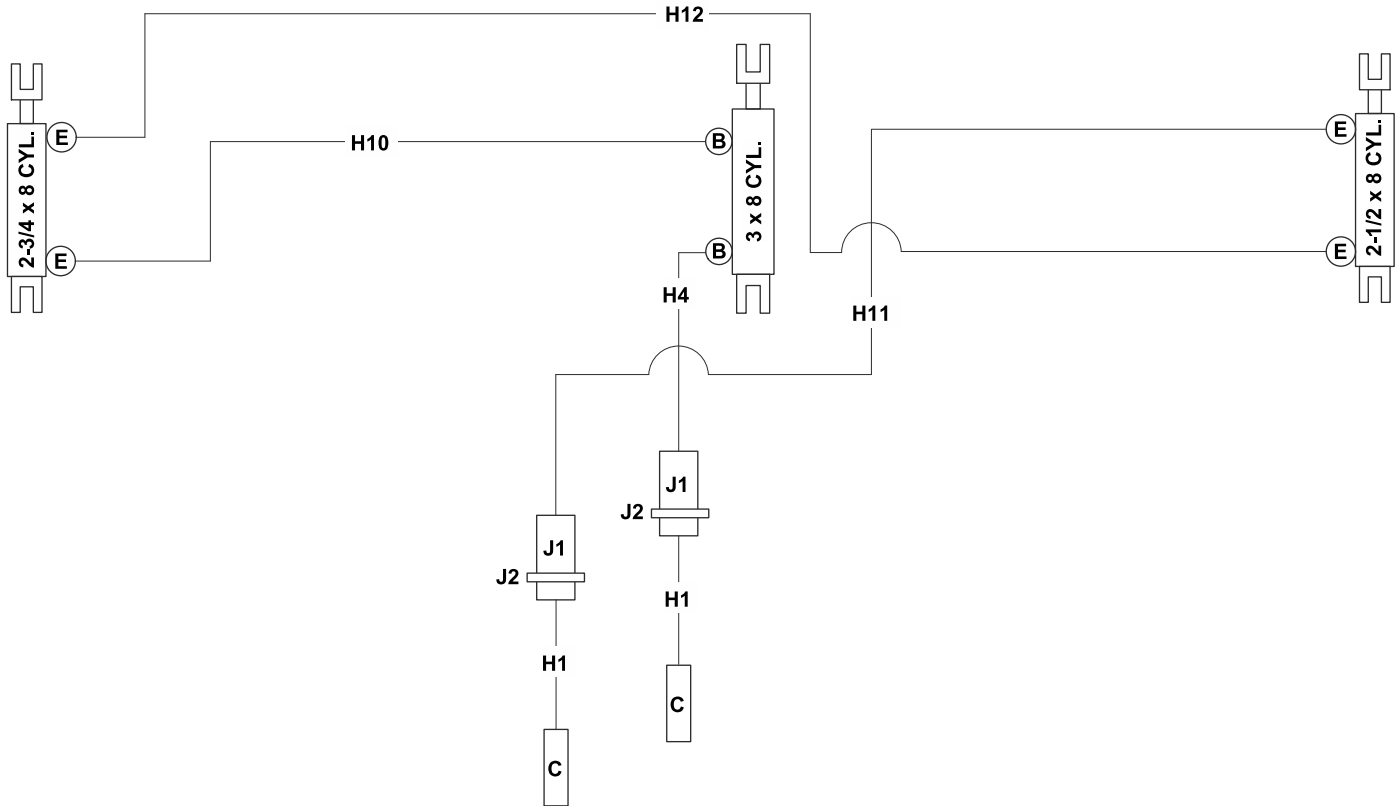

Hose / Hyd. Line / Fitting Number	Description	Qty.
H1	Hose 8MP-8FJX 216" Long - Lead Hose	2
H4	Hose 8FJX-8FJX 30" Long	1
H10	Hose 8FJX-8FJX 136" Long	1
H11	Hose 8FJX-8FJX 155" Long	1
H12	Hose 8FJX-8FJX 260" Long	1
B	FMBMJ9088 8MB-8MJ 90 Elbow	2
C	FFP08000PT 8FP Pioneer Tips	2
E	FMBMJ88C 8MB-8MJ Straight Coupling	4
J1	FMJMJH88 8MJ-8MJ Straight Bulkhead	2
J2	FHN88HN Bulkhead Nut	2

**Leveling Pipe Hydraulic Circuit**

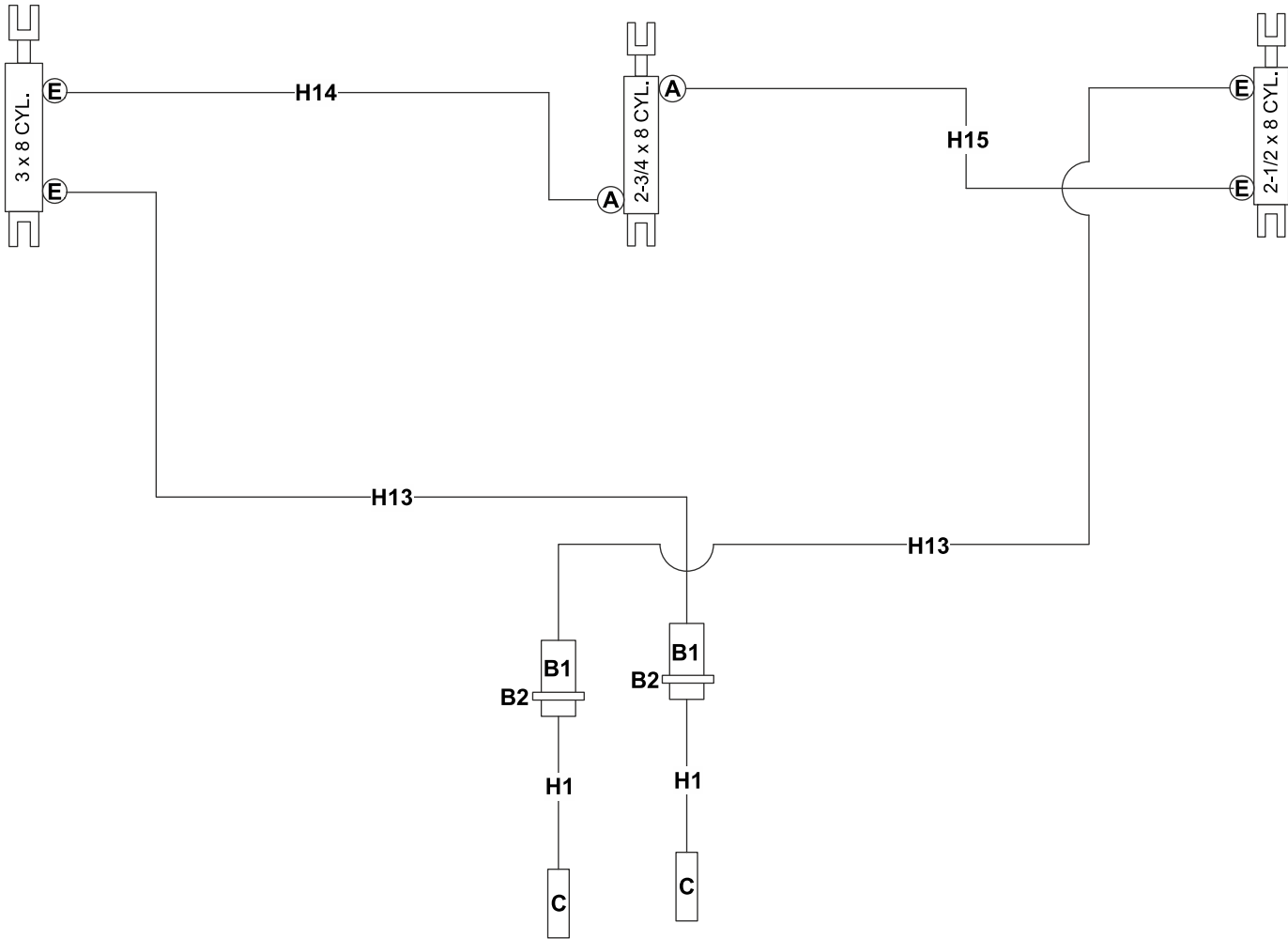

Hose / Hyd. Line / Fitting Number	Description	Qty.
H1	Hose 8MP-8FJX 216" Long - Lead Hose	2
H13	Hose 8FJX-8FJX 297" Long	2
H14	Hose 8FJX-8FJX 188" Long	1
H15	Hose 8FJX-8FJX 160" Long	1
B	FMBMJ9088 8MB-8MJ 90 Elbow	2
C	FFP08000PT 8FP Pioneer Tips	2
E	FMBMJ88C 8MB-8MJ Straight Coupling	4
J1	FMJMJH88 8MJ-8MJ Straight Bulkhead	2
J2	FHN88HN 8HN Bulkhead Nut	2

**Trail Hitch Hydraulic Circuit (Optional)**

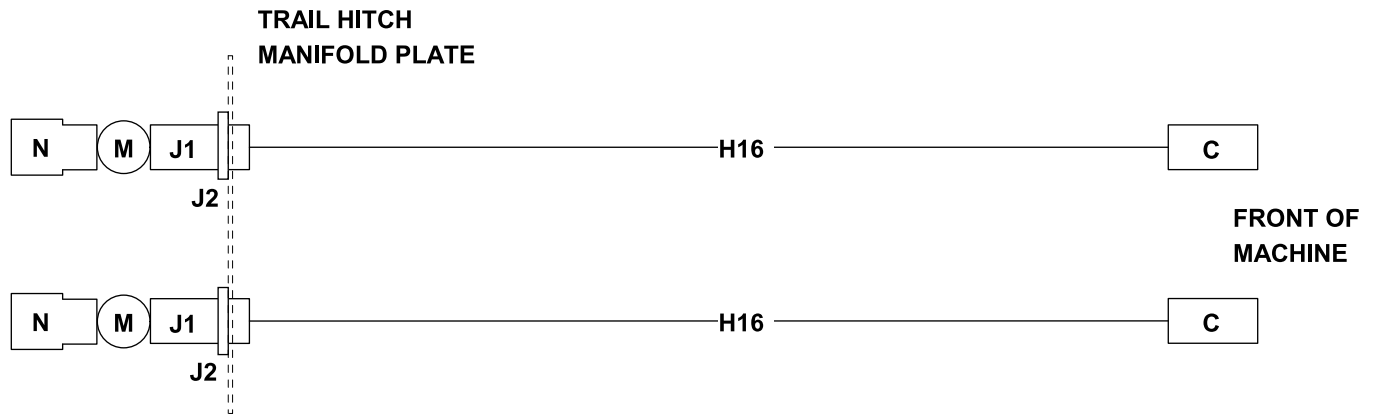

Hose / Fitting Number	Description	Qty.
H16	Hose 8MP-8FJX 408" Long - Lead Hose	2
C	FFP08000PT 8FP Pioneer Tips	2
J1	FMJMJH88 8MJ-8MJ Straight Bulkhead	2
J2	FHN88HN 8HN Bulkhead Nut	2
M	FMPFJX88 8MP-8FJX Straight Coupling	2
N	8FP Quick Attach Coupling	2
HKFTB4-TH	Hose Kit for Trail Hitch connection (includes all above items)	











---

## LIMITED WARRANTY STATEMENT

---

### T.G. Schmeiser Co., Inc.

P.O. Box 1392 – Selma, CA 93662

Phone (559) 268-8128 Fax (559) 268-3279

T. G. Schmeiser Co., Inc. warrants each new Schmeiser® product to be free from defects in material and workmanship. This warranty is applicable only for the normal service life expectancy of the product or components, not to exceed twelve (12) consecutive months from the date of delivery of the new Schmeiser product to the original purchaser.

Genuine T. G. Schmeiser Co., Inc. replacement parts and components will be warranted for 90 days from date of purchase, or the remainder of the original equipment warranty period, whichever is longer.

Under no circumstances will it cover any merchandise or components thereof, which, in the opinion of the company, has been subjected to misuse, unauthorized modifications, alteration, an accident or if repairs have been made with parts other than those obtainable through T. G. Schmeiser Co., Inc.

The Company in no way warrants engines, batteries, cylinders, tires or other trade accessories since these items are warranted separately by their respective manufacturer. Expendable components such as points, shanks, blades, rings, bearings, teeth, and the like are excluded from this warranty.

Our obligation under this warranty shall be limited to repairing or replacing, free of charge to the original purchaser, any part that, in our judgment, shall show evidence of such defect, provided further that such part shall be returned within thirty (30) days from date of failure to T. G. Schmeiser Co., Inc., routed through the dealer and distributor from whom the purchase was made, transportation charges prepaid.

This warranty shall not be interpreted to render T. G. Schmeiser Co., Inc. liable for injury or damages of any kind or nature to person or property. This warranty does not extend to the loss of crops, loss because of delay in harvesting, or any expense or loss incurred for labor, substitute machinery, rental or for any other reason.

**Except as set forth above, T. G. Schmeiser Co., Inc. shall have no obligation or liability of any kind on account of any of its equipment and shall not be liable for special or consequential damages. T. G. Schmeiser Co., Inc. makes no other warranty, expressed or implied, and, specifically, T. G. Schmeiser Co., Inc. disclaims any implied warranty or merchantability or fitness for a particular purpose. Some states or provinces do not permit limitations or exclusions of implied warranties or incidental or consequential damages, so the limitations or exclusion in this warranty may not apply.**

This warranty is subject to any existing conditions of supply, which may directly affect our ability to obtain materials or manufacture replacement parts.

T. G. Schmeiser Co., Inc. reserves the right to make improvements in design or changes in specifications at any time, without incurring any obligation to owners of units previously sold.

No one is authorized to alter, modify or enlarge this warranty nor the exclusion, limitations and reservations.

**WARRANTY VOID IF NOT REGISTERED  
WITHIN 30 DAYS OF PURCHASE DATE**



**P.O. Box 1392  
Selma, CA 93662  
(559) 268-8128  
WEB: [www.TGSchmeiser.com](http://www.TGSchmeiser.com)**

